

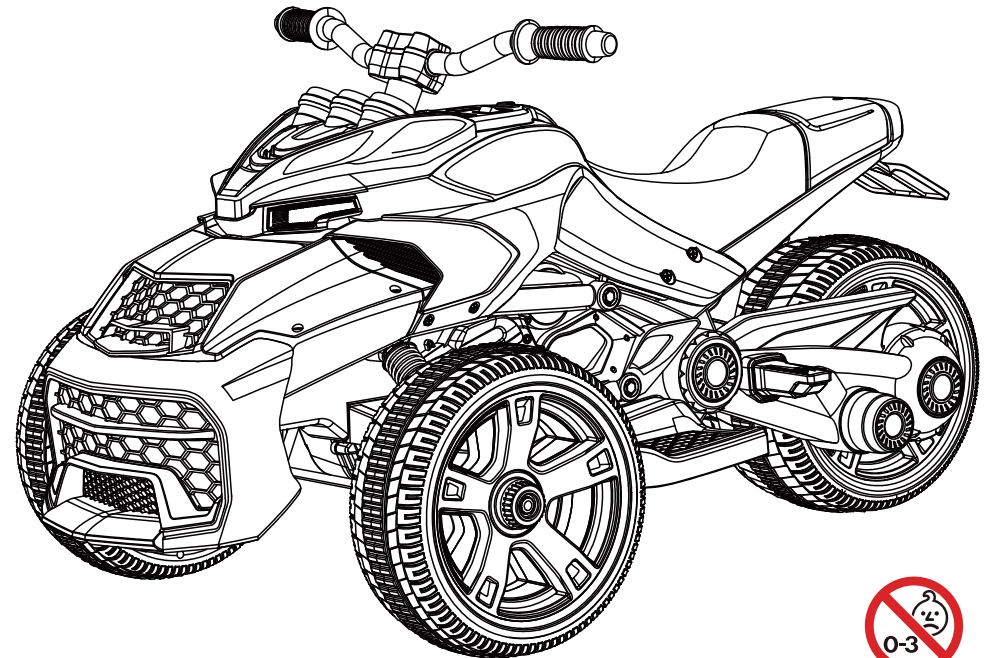

FREDDO

2 SEATER SPIDER



OWNERS MANUAL

with Assembly Instructions

Read and understand this entire manual before using!

Please keep this manual for future reference as it contains important information. Before first time use, charge the battery for at least 4-6 hours, but no more than 10 hours.

The battery features a thermal fuse with a reset fuse that will automatically trip and cut all power to the vehicle if the motor, electric system or battery is overloaded. The fuse will reset and power will be restored after the unit is turned OFF for 20 seconds and then turned ON again. If the thermal fuse trips repeatedly during normal use, the vehicle may need repair. **Contact your distributor please.**

To avoid losing power, follow these guidelines:

- Do not overload the vehicle.
- Do not tow anything behind the vehicle.
- Do not drive up steep slopes.
- Do not drive into fixed objects, which may cause the wheels to spin, causing the motor to overheat.
- Do not drive in very hot weather, components may overheat.
- Do not allow water or other liquids to come in contact with the battery or other electric components.
- Do not tamper with the electric system. Doing so may create a short, causing the fuse to trip.



RISK OF FIRE. Do not bypass. Replace only with a new fuse.

On the purchase of your new Ride-On.

This ride-on car will provide your child with many miles of riding of enjoyment. To help assure you and your rider a safe ride we ask you to please read this manual carefully, and keep it for future reference.

Follow the recommendations in this manual, they are designed to improve the safety and operation of your ride-on car and its rider.

Specification

| | | | |
|------------------------|-------------------------|---------------------|---------------------|
| Battery | 12V4.5AH X1 | 12V7AH X1 | 12V10AH X1 |
| Charger | 12V500mA | 12V1000mA | 12V1000mA |
| input | Depend on local voltage | | |
| Motor | 390-20000/550-12000 | 390-20000/550-12000 | 390-20000/550-12000 |
| Steering motor if have | 390-5000 | 390-5000 | 390-5000 |

- Suitable age:** 37-96 months
- Charge time:** 8~12 hours
- Load capacity:** 30KGS/66LBS
- Size of car:** 113*74*60 CM /44.48*29.13*23.62 INCH
- Speed:** 3-7KM/H /1.62-3.78PMH

Parts List

2

| PART NO. | PART NAME | Q'ty (pcs) | | REMARKS |
|----------|---------------------------|------------|--|----------|
| | | | | |
| 1 | Vehicle body | 1 | | |
| 2 | Front wheel | 2 | | |
| 3 | Ø12 washer | 4 | | |
| 4 | Lock nut | 2 | | |
| 5 | Hubcap | 2 | | |
| 6 | Front axle | 1 | | |
| 7 | Steering column | 1 | | |
| 8 | Ø4x16 screw | 5 | | |
| 9 | Front foot pedal (R) | 1 | | |
| 10 | Front foot pedal (L) | 1 | | |
| 11 | Rear foot pedal | 2 | | |
| 12 | M5x30 machine screw | 1 | | |
| 13 | Ø5 lock nut | 1 | | |
| 14 | Handle bar | 1 | | |
| 15 | Seat | 1 | | |
| 16 | Spanner | 1 | | |
| 17 | Charger | 1 | | |
| 18 | Remote controller if have | 1 | | optional |
| | | | | |

Assembly tools required (included):



Screwdriver

Maintaining

15

- It is parents' responsibility to check main parts of the toy before using, must regularly examine for potential hazard, such as the battery, charge, cable or cord, plug, screws are fastening enclosure of other parts and that in the event of such damage, the toy must not be used until that damage had been properly removed.
- Make sure the plastic parts of the vehicle are not cracked or broken.
- Occasionally use a lightweight oil to lubricate moving parts such as wheels.
- Park the vehicle indoors or cover it with a tarp to protect it from wet weather.
- Keep the vehicle away from sources of heat, such as stoves and heaters. Plastic parts may melt.
- Recharge the battery after each use. Only an adult can handle the battery. Recharge the battery at least once a month when the vehicle Raider is not being used.
- Do not wash the vehicle with a hose. Do not wash the vehicle with soap and water. Do not drive the vehicle in rainy or snowy weather. Water will damage the motor, electric system and battery.
- Clean the vehicle with a soft, dry cloth. To restore shine to plastic parts, use a non-wax furniture polish. Do not use car wax. Do not use abrasive cleaners.
- Do not drive the vehicle in loose dirt, sand or fine gravel which could damage the moving parts, motors or the electric system.
- When not using, all the electrical source should be turn off. Turn off the power switch and disconnect the battery connection.

Battery Disposal



The battery will eventually lose the ability to hold a charge. Depending on the amount of use, and varying conditions, the battery should operate for one to three years.

Important! Recycle the dead battery responsibly. The battery contains lead acid (electrolyte) and must be disposed of properly and legally. It is illegal in most areas to incinerate lead acid batteries or dispose of them in landfills. Take it to a federal or state-approved lead acid battery recycler, such as local automotive battery retailer.

Do not throw the battery away with your regular household waste!

| Problem | Possible Cause | Solution |
|--|---|--|
| Vehicle does not run | Battery low on power | Recharge battery. |
| | Thermal fuse has tripped | Reset fuse, see <Fuse> |
| | Battery connector or wires are loose | Check that the battery connectors are firmly plugged into each other. If wires are loose around the motor contact your distributor please. |
| | Battery is dead | Replace battery, contact your distributor please. |
| | Electrical system is damaged | Contact your distributor please. |
| | Motor is damaged | Contact your distributor please. |
| Vehicle does not run very long | Battery is under charged | Check that the battery connectors are firmly plugged into each other when recharging |
| | Battery is old | Replace battery, contact your distributor please. |
| Vehicle runs sluggishly | Battery low on power | Recharge battery, contact your distributor please. |
| | Battery is old | Replace battery, contact your distributor please. |
| | Vehicle is overload | Reduce weight on vehicle. |
| | Vehicle is being used in harsh conditions | Avoid using vehicle in harsh conditions ,see <Safety>. |
| Vehicle needs a push to go forward | Poor contact of wires or Connectors | Check that the battery connectors are firmly plugged into each other. If wires are loose around the motor, contact your distributor please. |
| | "Dead Spot" on motor | A dead spot means the electric power is not being delivered to the terminal connection and the vehicle needs repair. Contact your distributor please. |
| Difficult shifting from forward to reverse or vice-versa | Attempting to shift while the vehicle is motion | Completely stop the vehicle and shift, see <Use Your New Vehicle> |
| Loud grinding or clicking noises coming from motor or gear box | Motor or gears are damaged | Contact your distributor please. |
| Battery will not recharge | Battery connector or adapter connector is loose | Check that the battery connectors are firmly plugged into each other. |
| | Charger not plugged in | Check that the battery charger is plugged into a working wall outlet. |
| | Charger is not working | Contact your distributor please. |
| Charger feels warm when recharging | This is normal and not a cause for concern | |

Completely read through this manual and the troubleshooting guide table before calling. If you still need help resolving the problem **Contact your distributor please.**

HINT: Some parts shown are assembled on both sides of vehicle

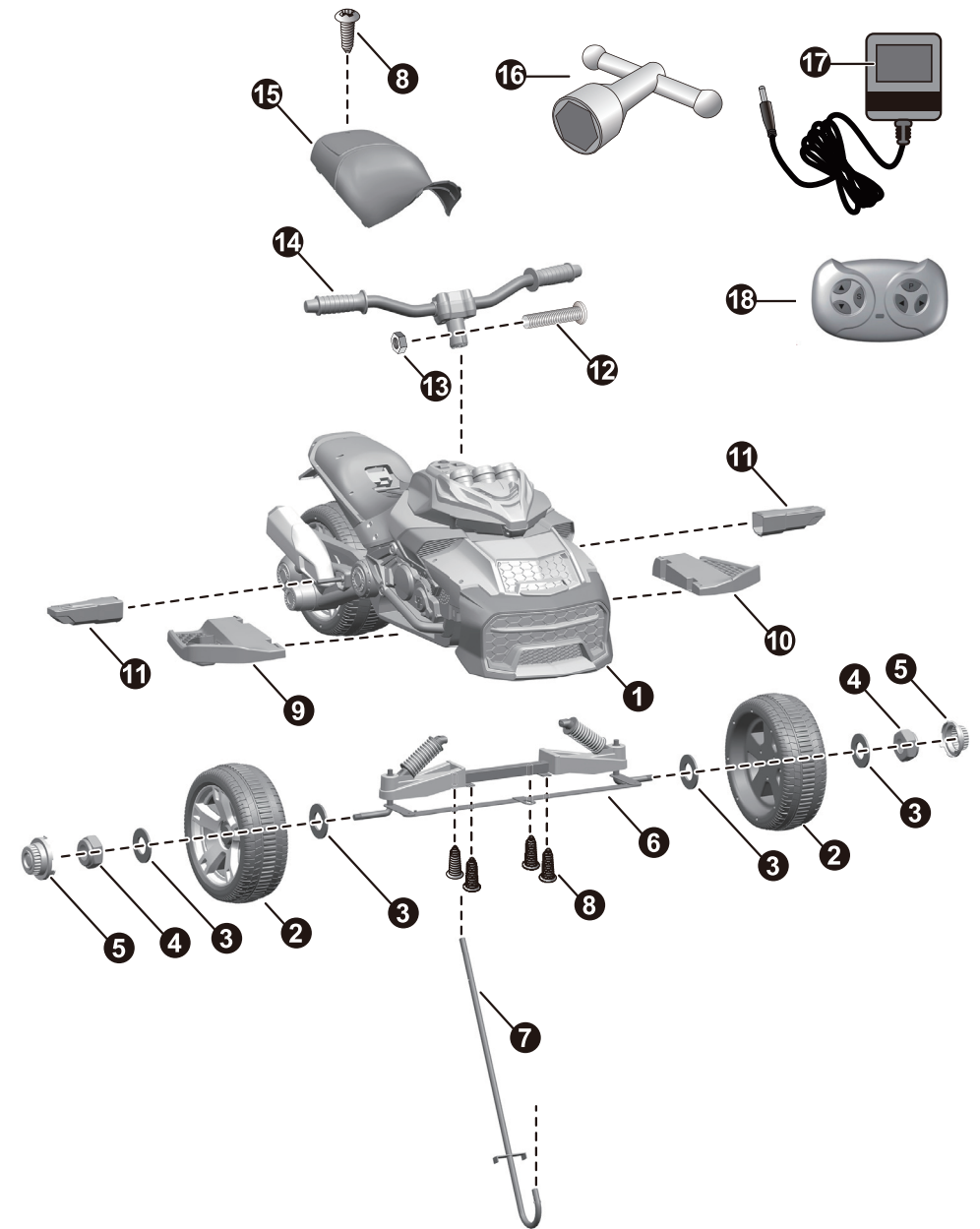

⚠ WARNING!

- **CHOKING HAZARD** - Small parts. Not suitable for children under 36 months. The product contains small parts, keep children away when assembling.
- **ADULT ASSEMBLY REQUIRED.**
- Always remove protective material and poly bags and dispose before assembly.
- Protective equipment should be worn. Always wear shoes and sit in the seat when operating the vehicle.
- Only drive on level ground. Never use on the lawn.
- Never leave a child unattended.
- Keep your hands, hair, and clothes away from moving parts.

⚠ SAFETY

The following safety hazards may result in serious injury or death:

- Never leave child unattended. Direct adult supervision is required. Always keep child in view when child is in vehicle.
- To reduce the risk of injury, adult supervision is required. Never use in roadways, near motor vehicles, on or near steep inclines or steps, swimming pools or other bodies of water, always wear shoes, and never allow more than 2 rider.
- Never use in unsafe conditions such as snow, rain, loose dirt, mud, sand, or gravel, otherwise may result in an unexpected accident such as tipping over, and could damage the electrical system or battery
- Not to be used in traffic.
- This toy should be used with caution since skill is required to avoid falls or collisions causing injury to the user or third parties.
- This toy is unsuitable for children under 36 months due to its maximum speed; Maximum user weight is 30kgs/66lbs
- This toy has no brake.

⚠ BATTERY INFORMATION

- Non-rechargeable batteries are not to be recharged.
- Rechargeable batteries are to be removed from the toy before being charged.
- Rechargeable batteries are only to be charged under adult supervision.
- Different types of batteries or new and used batteries are not to be mixed.
- Batteries are to be inserted with the correct polarity.
- Exhausted batteries are to be removed from the toy.
- The supply terminals are not to be short-circuited.

⚠ WARNING!

- **ONLY an adult is allowed charge and recharge the battery!**
- **This product with Charging Protection: when charging, all functions will be cut off.**

- Turn off the product when charging.
- Before the first use, you should charge the battery for 4-6 hours. Do not recharge the battery for more than 10 hours to avoid overheating the charger.
- When the vehicle begins to run slowly, recharge the battery.
- After each use or once a month minimum recharge time as 8 to 12 hours, less than 20 hours at most.
- Use the only rechargeable battery and charger supplied with your vehicle. NEVER substitute the battery or the charger with another brand. Using another battery or charger may cause a fire or explosion.
- Do not use the battery or charger for any other product.

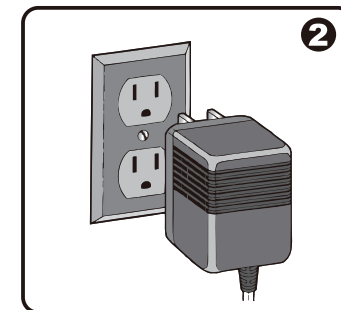
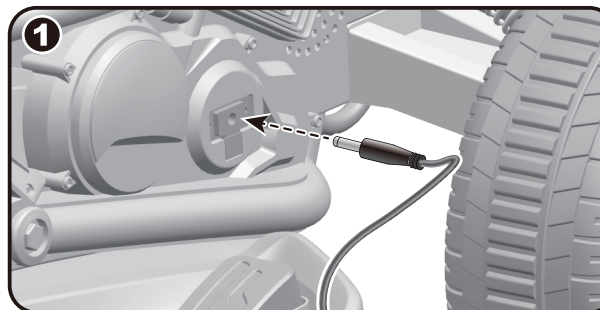

1. Plug the charger port into the input socket (the socket is above the **Throttle pedal**).
2. Plug the charger plug into a wall outlet. The battery will begin charging.

WARNING: The remote control is only allowed to be operated by adults.

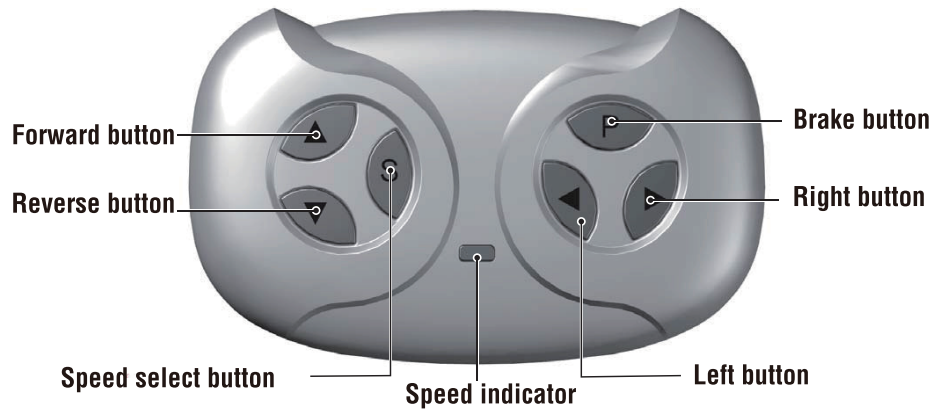

Attach the batteries of controller

Lift the battery compartment door on the back of the controller and insert two AAA(LR03) batteries.

HINT: Batteries not included. Refer to the Battery Information on the page 4.

1. Build connection

Long press the forward and reverse buttons for 3 seconds, and the speed indicator flashes. Then power on the vehicle, the speed indicator goes to long bright, means the connection successful. If the speed indicator no response, means the connection failed. Replace the batteries and retry.

2. Brake button

Press the button to stop the vehicle, press it again to release the brake.

3. Speed select button

The switch operates the vehicle to move in low, normal or high speed.

HINT: This switch won't work while your vehicle moves reverse.

NOTE:

- Leave the remote controller idling for about 10 seconds, it will shut down automatically.
- Rebuild connection when you replace the batteries of the remote controller.

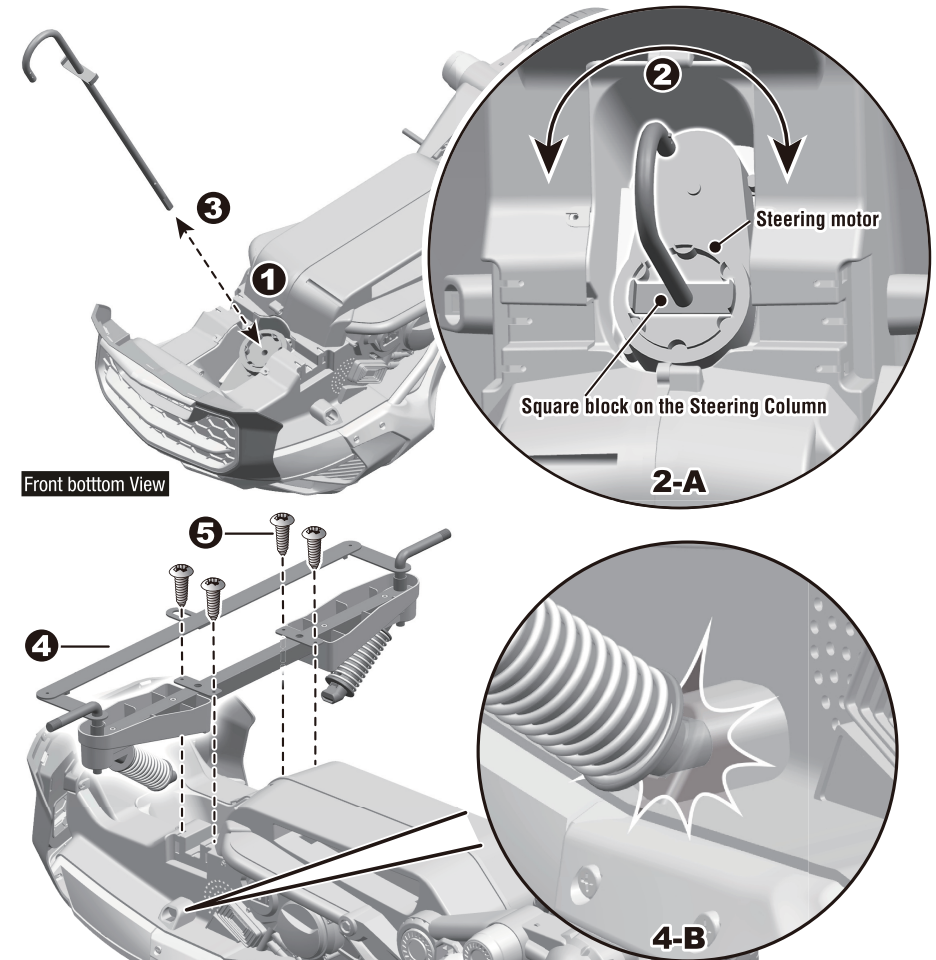

Turn the vehicle body upside down.

If there is no remote control function, ignore step 2 and step 3, and install according to step 4.

1-2. Insert the steering column through the hold in the steering motor on the vehicle body, and ensure the square block on the steering column clamp into the steering motor, then rotate the steering column firmly to make it in the position as shown in the figure 2-A.

3. Remove the steering column so that the front axle can be assembled to the body.

4. Fit the front axle to the vehicle body. Make sure that the two shock absorbers on the front axle snap into the holes in the body. (4-B)

5. Insert four \varnothing 4x16 screws and tighten with a screwdriver.

Attach the Rear Wheels

6

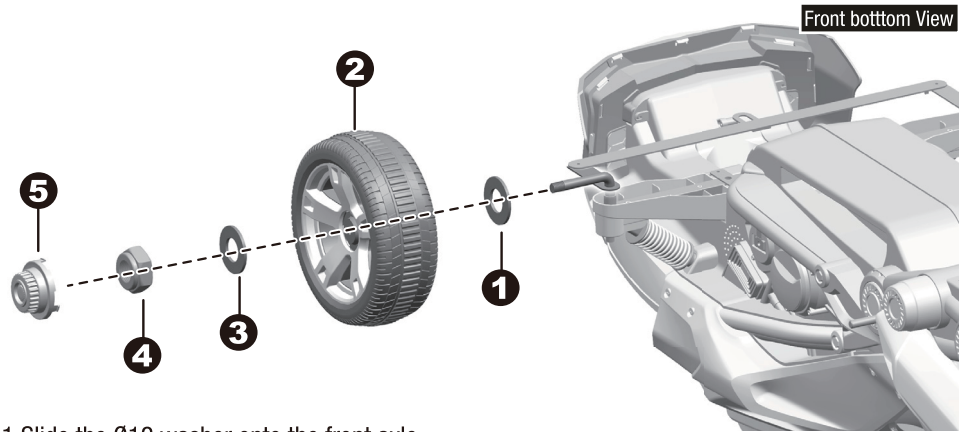

1 Slide the $\varnothing 12$ washer onto the front axle.

2. Slide a wheel onto the front axle.

3. Slide the $\varnothing 12$ washer onto the front axle.

4. Tighten a lock nut to the end of the front axle with a spanner.

5. Fit the hubcap to the front wheel.

Repeat the procedure to assemble the other front wheel.

Use

11

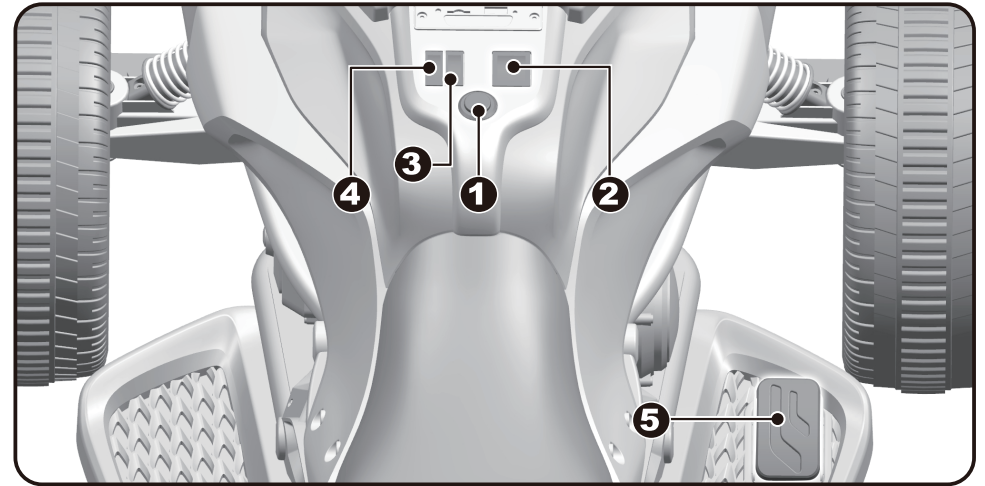

1. Power button: Turns the product on and off.

2. Forward/reverse switch: Changes the direction that vehicle moves from forward to reverse.

- To move the vehicle forward, shift the lever to top position.
- To move the vehicle backward, shift the lever to down position.

3. High/Low speed switch: Operates the product to move forward in high or low speed.

HINT: The product is designed to operate in low speed only in reverse.

4. Lights switch: Turns the lights on and off.

5. Throttle pedal: Applies power (speed) to the product.

- To move the product, press the pedal down.
- To brake or slow down, release pressure from the pedal.

IMPORTANT

- **Always stop vehicle when changing the speed or direction to avoid damage the gears and motor.**
- **HIGH SPEED:** Make sure your child knows how to steer, how to start and stop the product and knows the rules for safe driving.

Attach the Shock absorber

8

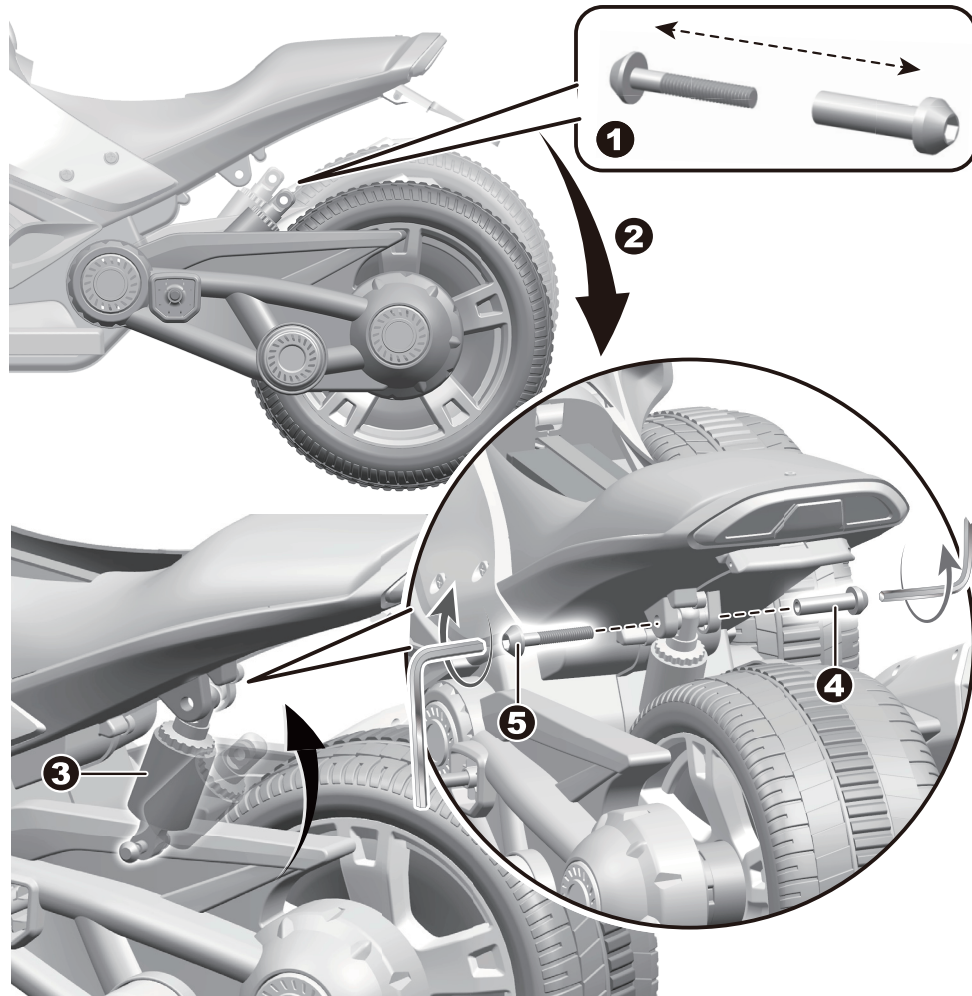

1. Remove the shock screw, and the nut from the rear shock absorbers with two hex wrenches.
- 2-3. Adjust the vehicle body and shock absorbers, and align the holes on the body and shock absorber.
- 4-5. Then fix them with the screw and nut removed in step one.

Attach the Front Foot Pedals

9

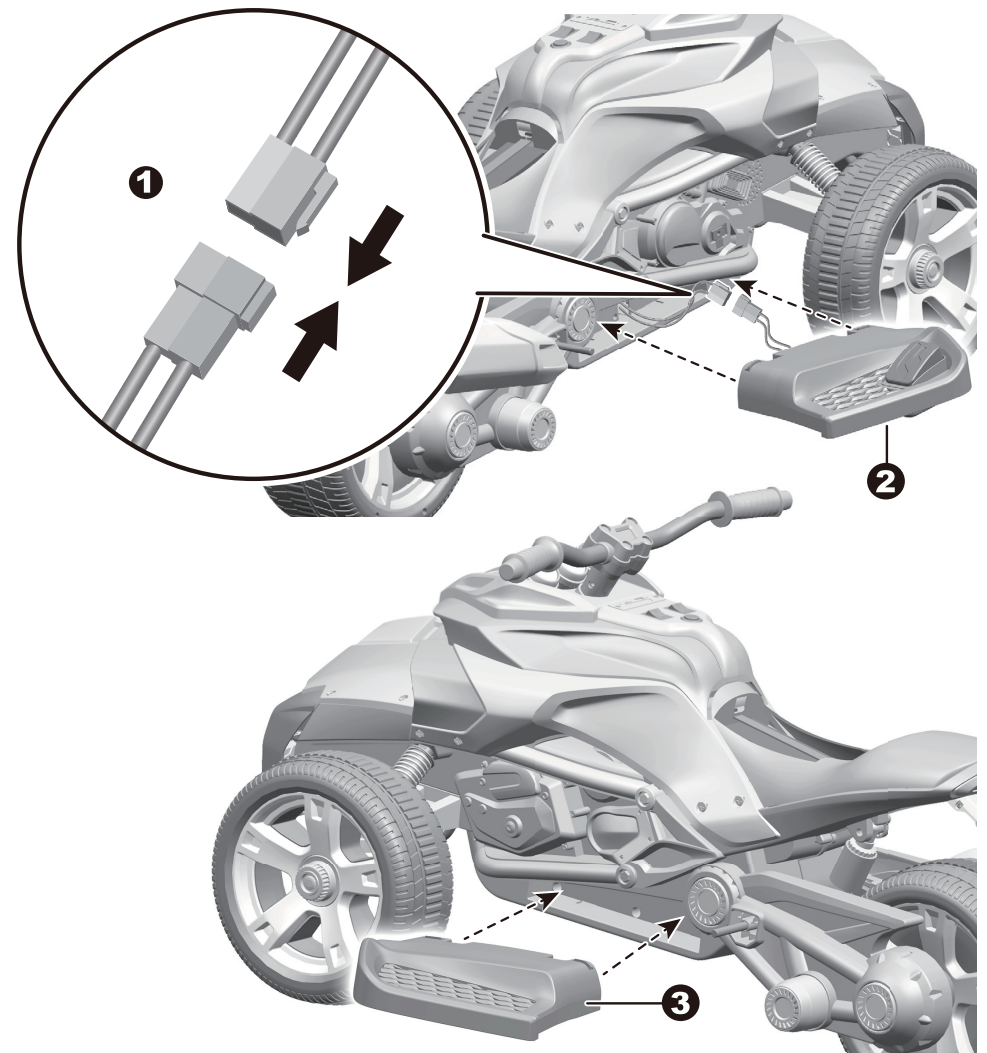

1. Plug the connector on the front foot pedal (R) into the connector from the vehicle body.
2. Fit the front foot pedal (R) to the vehicle body. Push until you hear it “click” into place.
3. Fit the front foot pedal (L) to the vehicle body. Push until you hear it “click” into place.