



BENTLEY

BENTLEY BENTAYGA

BATTERY OPERATED RIDE-ON



Owner's Manual with Assembly Instructions

Styles and colo(u)rs may vary.
Made in China.

The owner's manual contains important safety information as well as assembly, use and maintenance instructions.

The Ride-on Car must be assembled by an adult who has read and understands the instructions in this manual.

Keep the package away from children and dispose of properly before use.

Keep this manual for future reference.

On the purchase of your new Bentley Ride-On.

This ride-on car will provide your child with many miles of riding of enjoyment. To help assure you and your rider a safe ride we ask you to please read this manual carefully, and keep it for future reference.

Follow the recommendations in this manual, they are designed to improve the safety and operation of your ride-on car and it's rider.

The Bentley Bentayga Battery operated Ride-On Manufactured by Zhejiang Jiajia Ride-On Co., Ltd (Add: Xincang Industrial Zone, Pinghu City, Zhejiang Province, P.R.China) under licence from Bentley Motors Limited England. "Bentley", the 'B' in wings device and other associated logos and names are trademarks of Bentley Motors Limited. The body designs of Bentley motor cars are protected by Bentley Motors Limited under design, trademark and trade dress regulations.

Battery	6V7Ah*1 or 6V10 *1	6V7Ah*2
Charger	6V1000mA	12V1000mA

Suitable age: 37~96 Months

Load Capacity: Under 30 kgs

Speed: 1WD: 2.5 km/h 2WD:2.5~5 km/h

Size of car: 125 x 73.4 x 58 CM

Power way: Charging type

Charge time: 8 ~ 12 hours

Parts List | 2

PART NO.	PART NAME	Q'ty (pcs)		REMARKS
		1WD	2WD	
1	Vehicle body	1		
2	Gear box	1	2	2WD One labeled "L", and the other one labeled "R"
3	Driving wheel	1	2	
4	Normal wheel	3	2	
5	Bush	3	2	
6	Ø12 washer	8	6	
7	Motor hood	1	2	
8	Ø4x12 flat head screw	4	8	
9	Lock nut	4		
10	Hubcap	4		
11	M5x16 machine screw	2		for seat
12	Seat	1		
13	Mirror	2		Left and right
14	Steering Wheel	1		
15	M5x35 machine screw	1		Placed on the steering wheel
16	Ø5 nut	1		Placed on the steering wheel
17	Charger	1		
18	Spanner	2		
19	Remote controller	1		IF EQUIPPED, for R/C type only

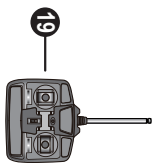

CONTROLLER STYLES MAY VARY

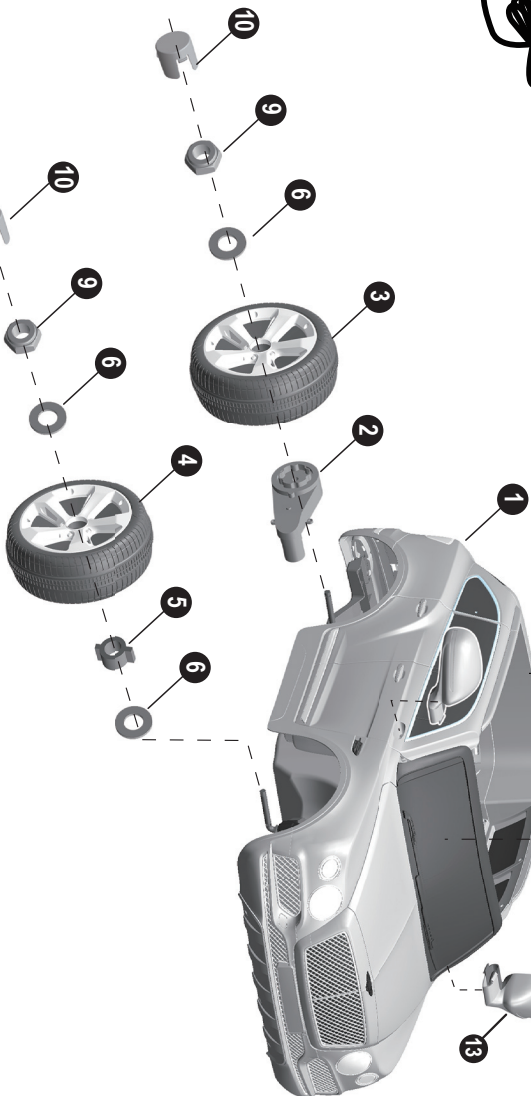
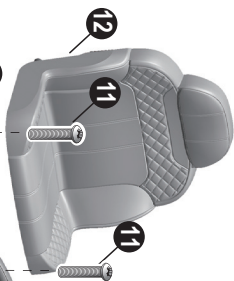
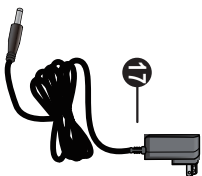

HINT: Some parts shown are assembled on both sides of vehicle

WARNING!

- **CHOKING HAZARD** - Small parts. Not suitable for children under 36 months. The product contains small parts, keep children away when assembling.
 - **ADULT ASSEMBLY REQUIRED.**
 - Always remove protective material and poly bags and dispose before assembly.
-
- Make sure that the power switch is **turned “OFF”** before assembling the ride-on.
 - Before first time use, charge the battery for at least 4 to 6 hours.
 - Assembly tools required:

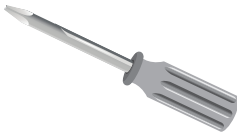

Screwdriver
(not included)

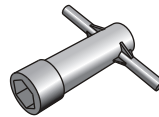

Spanner

BATTERY INFORMATION

- Non-rechargeable batteries are not to be recharged.
- Rechargeable batteries are to be removed from the toy before being charged.
- Rechargeable batteries are only to be charged under adult supervision.
- Different types of batteries or new and used batteries are not to be mixed.
- Batteries are to be inserted with the correct polarity.
- Exhausted batteries are to be removed from the toy.
- The supply terminals are not to be short-circuited.

HINT: If your vehicle is *Two Wheels Driving Type*, see the next page please.

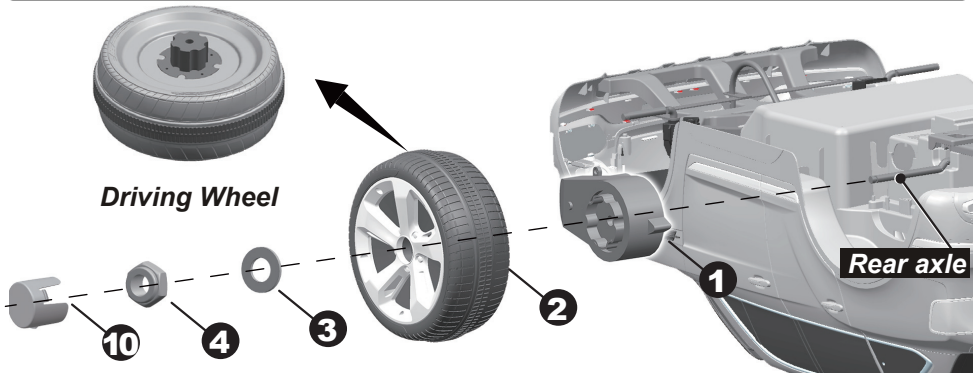

1. Slide the **gear box** onto the **rear axle (Left Side)**. Keep the **motor** and the **connector** on the gear box through the larger hole on the rear vehicle and out where the battery sits.
2. Slide the **driving wheel** onto the rear axle. And keep the **driving wheel** match with the **gear box**.
3. Slide the **Ø12 Washer** onto the **rear axle**.
4. Tighten a **Lock nut** to the end of the **rear axle** with a spanner.

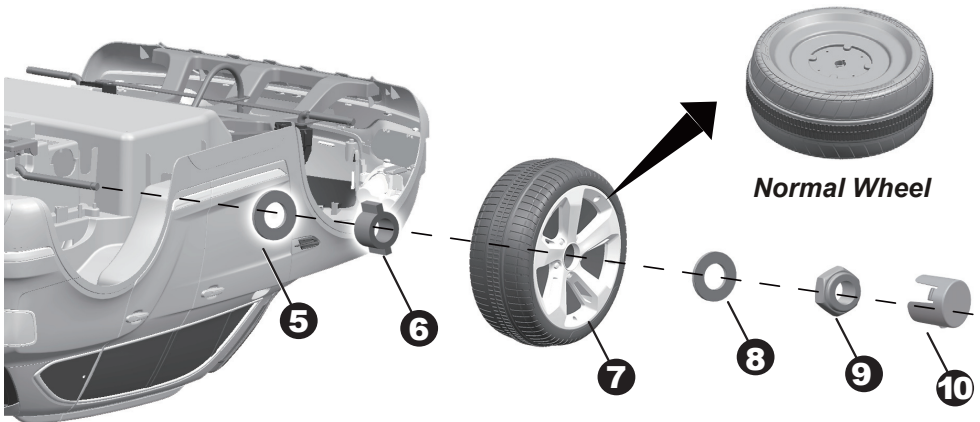

5. Slide the **Ø12 Washer** onto the **rear axle (Right Side)**.
6. Insert the bush into the hole in the center of the normal wheel.
7. Slide the **Normal wheel** onto the rear axle.
8. Slide the **Ø12 Washer** onto the **rear axle**.
9. Tighten a **Lock nut** to the end of the **rear axle** with a spanner. **HINT: An extra spanner has been provided to hold the Lock Nut on the other side of the rear axle while tightening the Lock Nut on the other side.**
10. Fit the **hubcaps** to the wheel.

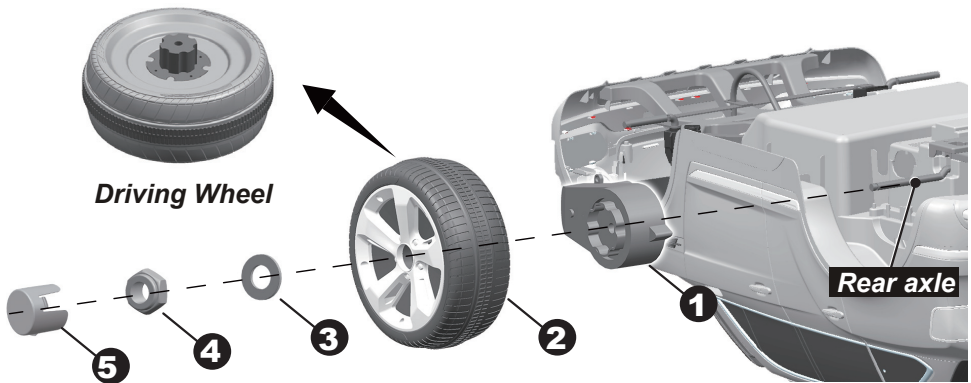

1. Slide the **gear box** onto the **rear axle**. "R" labeled gear box should be fit to the "R" side of vehicle body; "L" labeled gear box should be fit to "L" side of vehicle body. Keep the **motor** and the **connector** on the gear box through the larger hole on the rear vehicle and out where the battery sits.
2. Slide the **driving wheel** onto the rear axle. And keep the **driving wheel** match with the **gear box**.
3. Slide the **Ø12 Washer** onto the **rear axle**.
4. Tighten a **Lock nut** to the end of the **rear axle** with a spanner. **HINT: An extra spanner has been provided to hold the Lock Nut on the other side of the rear axle while tightening the Lock Nut on the other side.**
Repeat the above procedure to assemble the other driving wheel.
5. Fit the **hubcaps** to the wheel.

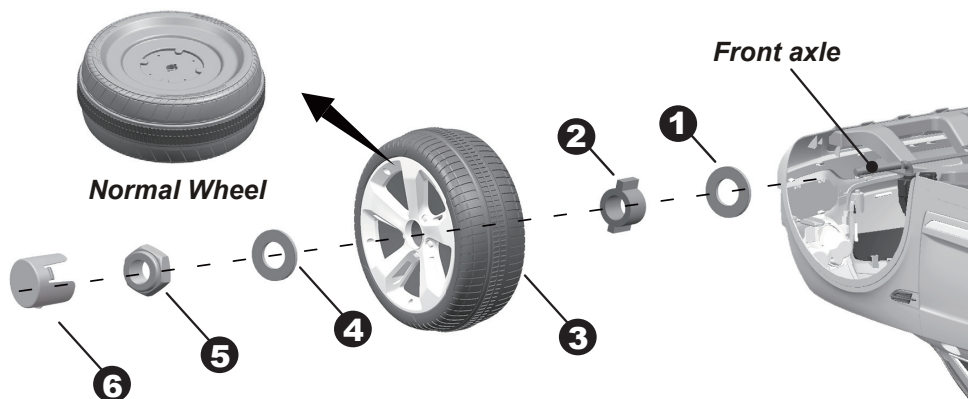

Remove all the parts from the front axle.

1. Slide a **Ø12 washer** onto the **front axle**.
2. Slide a bush into the hole in the center of the normal wheel.
3. Slide the **normal wheel** onto the rear axle. And keep the **normal wheel** match with the bush.
4. Slide a **Ø12 washer** onto the **front axle**.
5. Tighten a **Lock nut** to the end of the **front axle** with a spanner.
6. “Snap” the **hubcap** to the wheel.

Repeat the above procedure to assemble the other front wheel.

HINT: Batteries not included. Refer to the battery information on page 4.

Add the Batteries (Not included) of Steering Wheel

1. With a screwdriver remove the **screw** on the **battery cover** located in the center of the steering wheel.
2. Remove the **battery cover** from the top of the **battery compartment**.
3. Insert two **AA batteries** in their correct polarities.
4. Place the **battery cover** over the **battery compartment** and fasten with the **screw** you removed in step one.

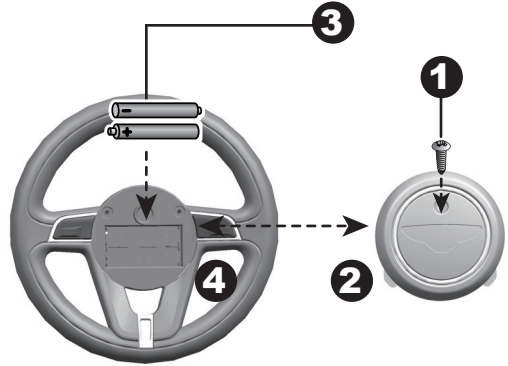

Attache the Steering Wheel

Remove the **M5x35 machine screw** and **Ø5 nut** from the **steering wheel**.

5. Place the **steering wheel** over the **steering column**, protruding from the middle of the **steering wheel base**.
6. Align the **holes** on each side of **steering wheel** with the holes at the **end of the steering column**.
7. Fasten a **nut** on the opposite end of the **screw** to secure the **steering wheel to the steering column**.

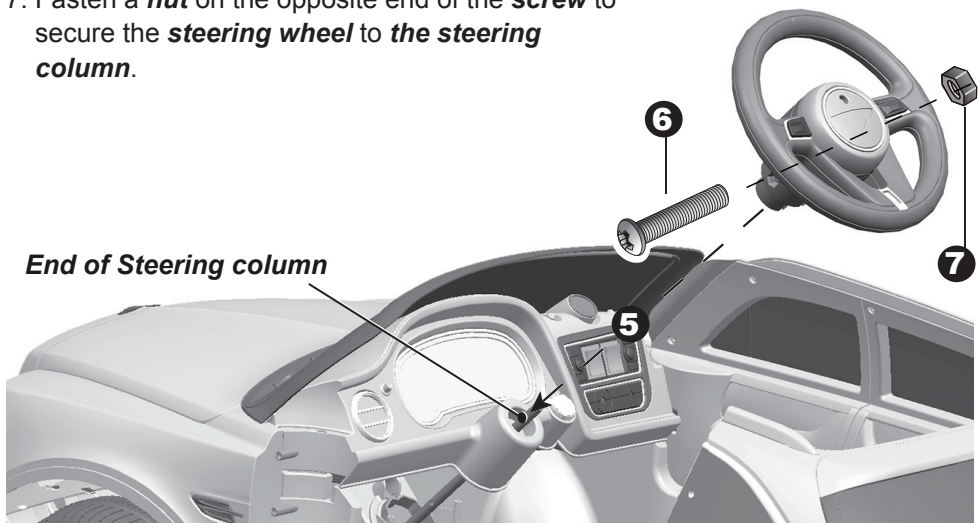

Rear Top View

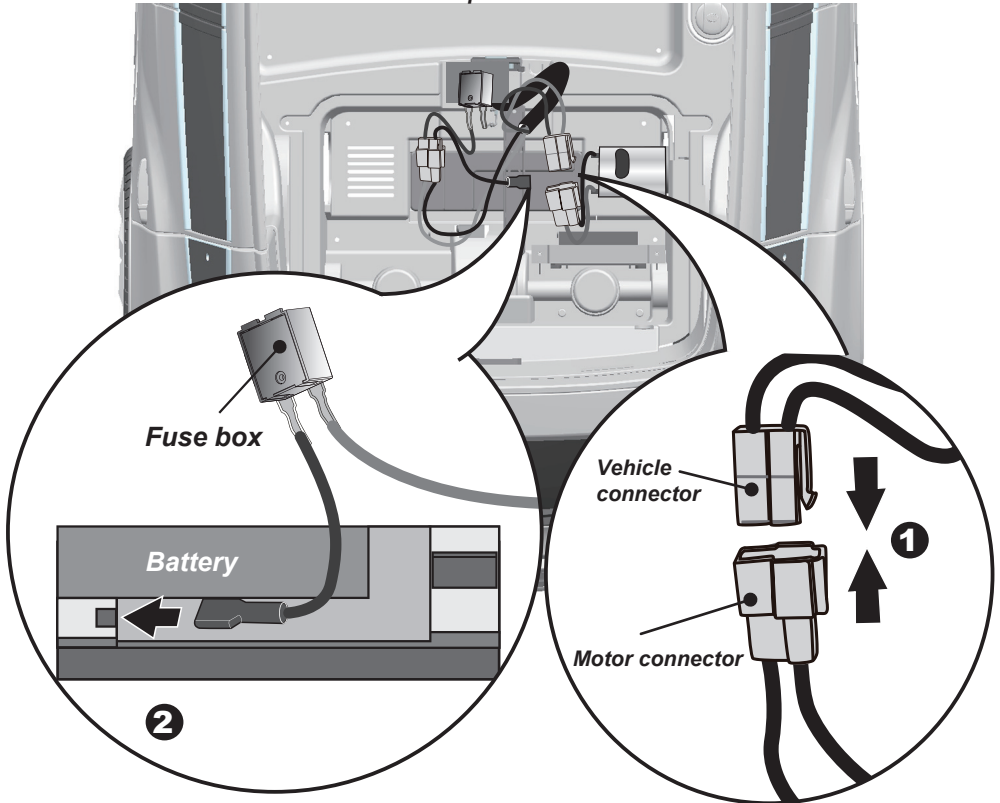

1WD

1. Plug the **Vehicle Connector** into the **Motor Connector** on body as shown above.
2. Plug the **Red fuse connector** into the **terminal on battery**.

2WD

1. Plug the **Vehicle Connector** into the **Motor Connector** on body as shown above. Repeat for the other side.
2. Plug the **Red fuse connector** into the **terminal on battery**.

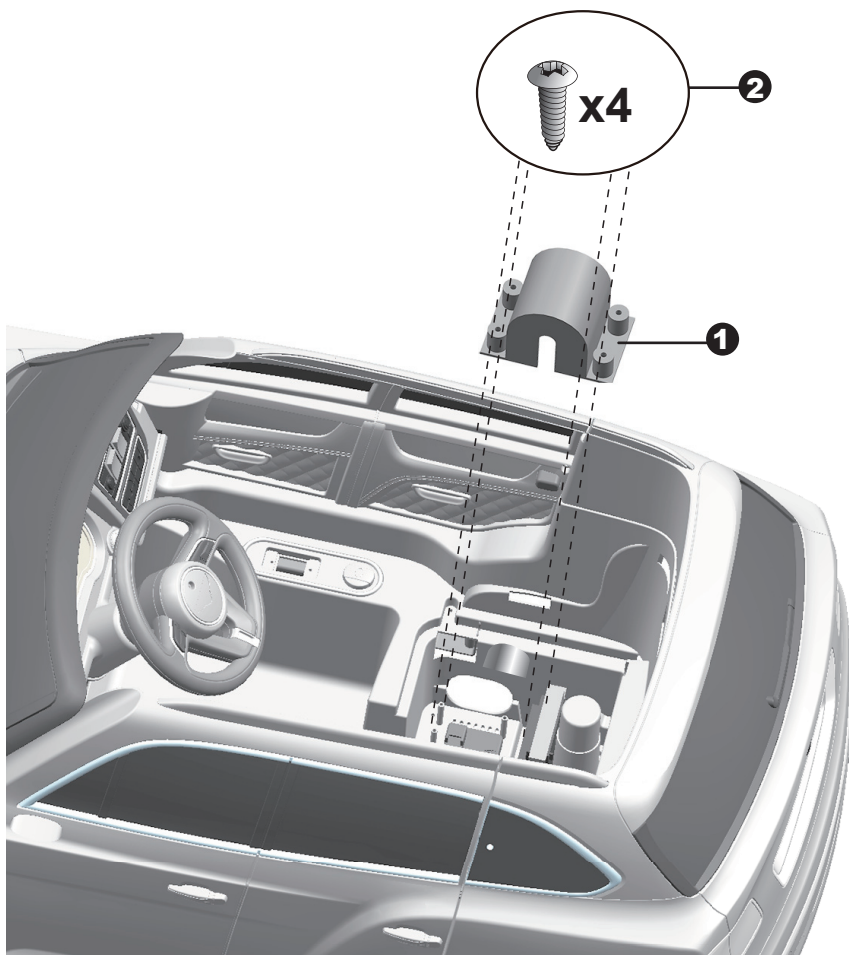

1WD

1. Fit the **motor hood** on the motor.
2. Tighten four **Ø4x12 flat head screws** to secure it.

2WD

1. Fit the **motor hood** on the motor.
2. Tighten four **Ø4x12 flat head screws** to secure it.
Repeat the above steps for the other **Motor hood**.

1. Fit the **tabs** on the back of seat into the slots on the rear vehicle.
2. Tighten two **M5x16 machine screws** to secure it with a screwdriver.

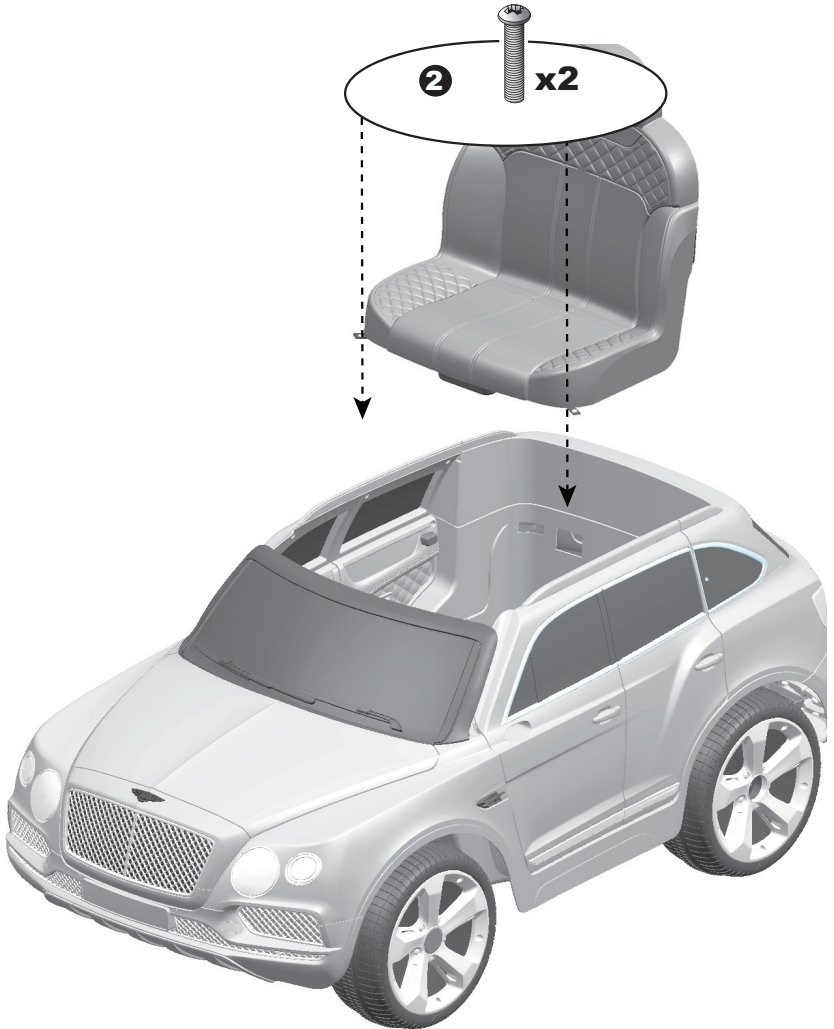

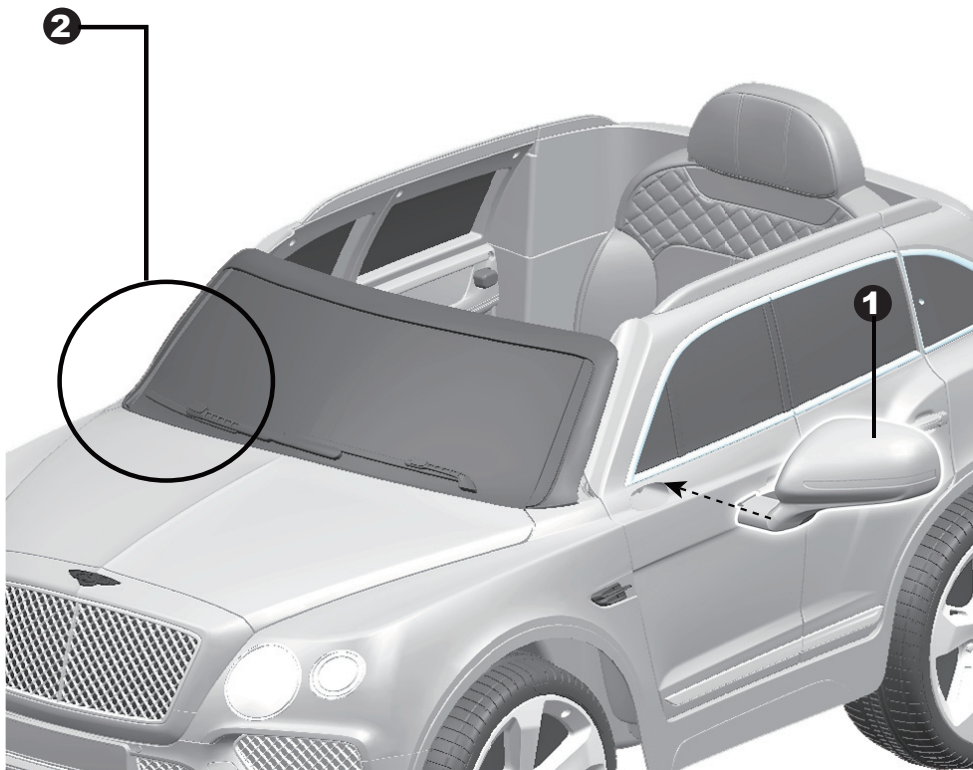

1. Fit the **mirror** into the hole on side of vehicle.
2. Repeat for the other side.

WARNING!

PREVENT INJURIES AND DEATHS:

- **NEVER LEAVE CHILD UNATTENDED. DIRECT ADULT SUPERVISION IS REQUIRED.** Always keep child in view when child is in vehicle.
- This toy should be used with caution since skill is required to avoid falls or collisions causing injury to the user or third parties.
- Protective equipment should be worn.
- Never use in roadways, near cars, on or near steep inclines or steps, swimming pools or other bodies of water.
- Always wear shoes.
- Always sit on the seat.
- Not to be used in traffic.
- This toy is unsuitable for children under 36 months due to its maximum speed; Maximum user weight is 30 kgs.
- This toy has no brake.

Rules for Safe Riding

- Keep Children within Safe Riding Areas:
 - Never use in roadway, near motor vehicles, on lawn space, on or near steep inclines or steps, swimming pools or other bodies of water;
- Use the toy only on flat surfaces. Such as inside your house, garden or playground.
- Never use in the dark. A child could encounter unexpected obstacles and have an accident. Operate the vehicle only in the daytime or a well-lit area.
- It is prohibited to change the circuit or add other electric parts
- Inspect wires and connections of the vehicle periodically.
- Do not let any child touch the wheels or be near them when the car is moving .
- This vehicle has adjustable play seat belts. Please instruct children how to tie the safety belt before using, guarantee the security.



Use the vehicle on generally level ground **ONLY!**

DO NOT Use the vehicle on Lawn space!

Your vehicle may be equipped with the Multi-Function dash, see the next page please!



Always stop vehicle when changing the speed or direction to avoid damage the gears and motor.

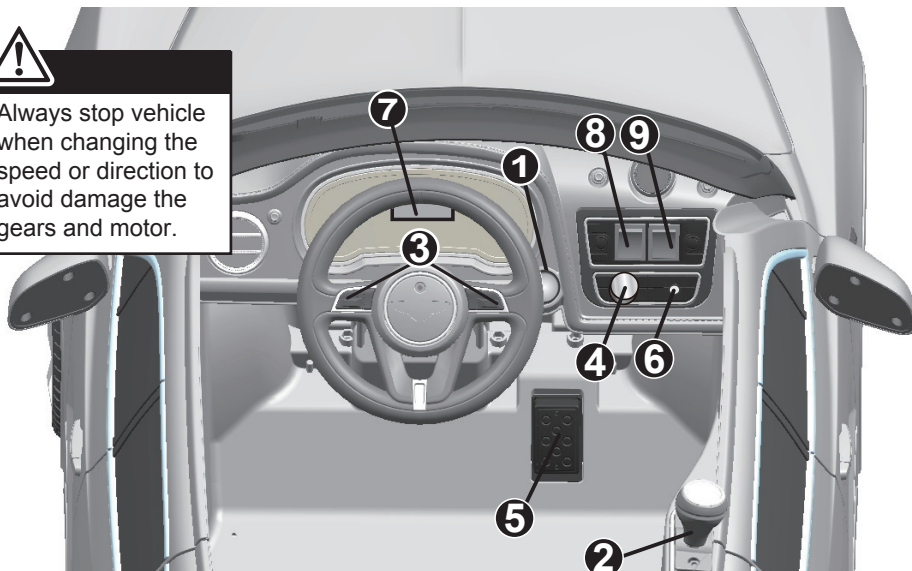

1. **Power Switch:** Turns the vehicle on and off.
2. **Forward/reverse switch:** Changes the direction that vehicle moves from forward to reverse.
 - To move the car forward, rock the switch to “forward” position.
 - To move the car backward, rock the switch to “reverse” position.
3. **Sounds buttons (IF EQUIPPED):** Press for sounds playing.
4. **Volume knob (IF EQUIPPED):** Turn the knob clockwise to increase the volume; Turn the knob counterclockwise to decrease the volume.
5. **Foot pedal:** Applies power (speed) to the vehicle.
 - To move the car, press the pedal down.
 - To brake or slow down, release pressure from the pedal.
6. **Auxiliary input (IF EQUIPPED):** Allow the audio from your portable music player or phone to be played through the vehicle speakers.
7. **Digital voltmeter (IF EQUIPPED):** See <Charging>, page 20.
8. **High/Low speed switch (IF EQUIPPED):** The switch operates the vehicle to move forward in low or high speed.
9. **Foot - R/C switch (IF EQUIPPED):** Change the operation mode, Foot-pedal operation or Remote Controller operation.



ADVANCED USE - High speed Drive

Make sure your child knows how to steer, how to start and stop the vehicle and knows the rules for safe driving. The vehicle can be driven at a maximum of 2.5~5 km/h.

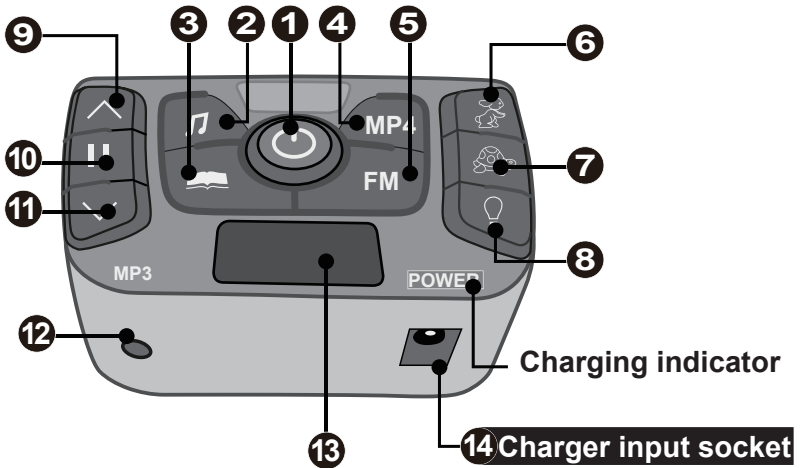

1. Power switch: Turn the vehicle on and off.
 2. Sounds button: Press for sounds playing;
 3. Storytelling mode : Press for storytelling.
 4. **NO Function.**
 5. FM button: Using the FM radio. Press it for 2-3 seconds, the radio will search station automatically.
 6. High speed: Driving the vehicle forward in high speed.
 7. Low speed: Driving the vehicle forward and reverse in low speed.
- HINT: The vehicle is designed to operate in low speed only in reverse.**
8. Lights button: Turn the lights of vehicle on and off.
 9. Previous /Increase volume: Long press for increasing the volume.
 10. Pause: Pause playing the music.
 11. Next / decrease volume: Long press for decreasing the volume.
 12. MP3 audio input connector: Allow the audio from your portable music player or phone to be played through the vehicle speakers.
 13. Digital voltmeter: Check the power remaining of your battery.
 14. Charging input socket.



WARNING:

ADULT OPERATING REQUIRED!

Your vehicle may be equipped with a **2.4G REMOTE CONTROLLER**, see the next page please.

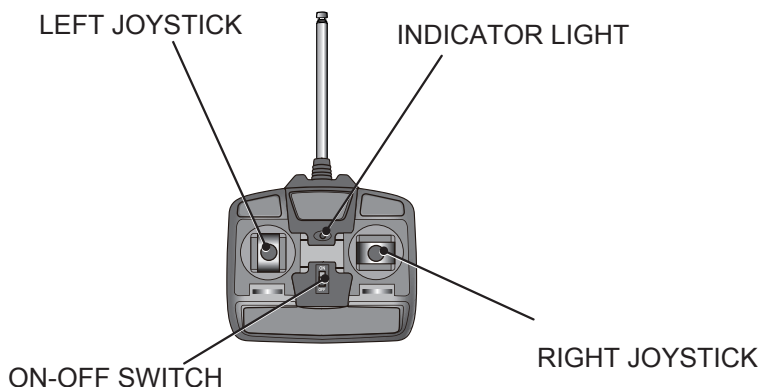

This remote controller may with function of firt priority

The remote control has precedence over foot pedal operation.
(The foot pedal won't work while you operate the Remote Controller)

ASSEMBLY

1. Insert the antenna into the controller by tweak the antenna clockwise;
2. Lift the battery compartment door on the back of the controller and insert two AA(LR6) batteries.

NOTE: Batteries not included.

Refer to the battery information on page 4.

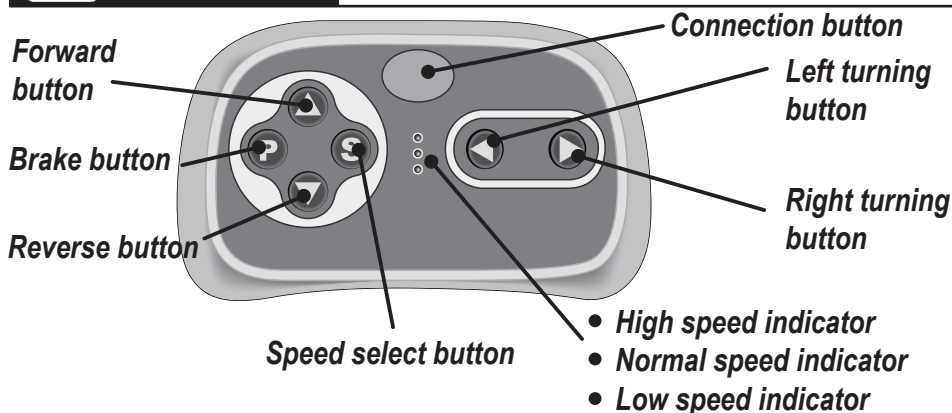
**WARNING:****ADULT OPERATING REQUIRED!**

The remote control has precedence over foot pedal operation.

(The foot pedal won't work while you operate the Remote Controller)

ASSEMBLY

Lift the battery compartment door on the back of the controller and insert two AAA(LR03) batteries.

NOTE: Batteries not included.

Refer to the battery information on page 4.

1. Connection button (build connection)

Long press the **Connection button** for 2~4 seconds first; Then turn on the power button located on the vehicle dashboard console, when the low speed indicator goes from **flashes into long bright**, means the connection successful. If the low speed indicator only **flashes**, means the connection failed. Replace the batteries and repeat the steps above.

2. Brake button

Press the button to stop the vehicle, press it again to release the brake.

3. Speed select button

The switch operates the vehicle to move in low, normal or high speed.

HINT: The vehicle is designed to operate in low speed only in reverse.

NOTE:

- Leave the remote controller idling for about 10 seconds, it will shut down automatically.
- Repeat step 1 when you replace the batteries of the remote controller.

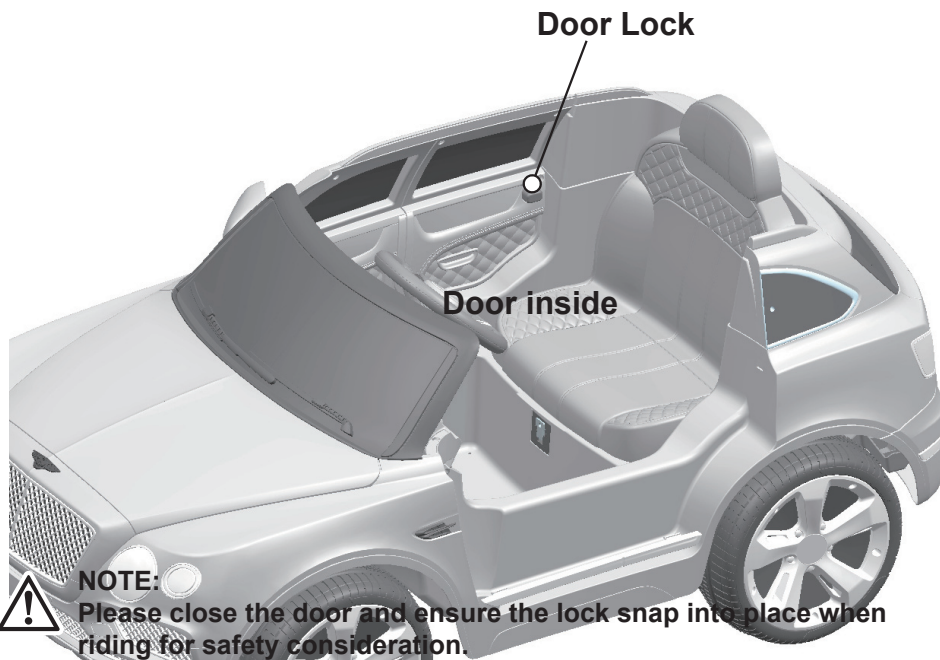

ONLY AN ADULT CAN CHARGE AND RECHARGE THE BATTERY!



WARNING!

- **PREVENT FIRE AND ELECTRIC SHOCK:**

- Use the only rechargeable battery and charger supplied with your vehicle. NEVER substitute the battery or the charger with another brand. Using another battery or charger may cause a fire or explosion.
- Do not use the battery or charger for any other product. Overheating, fire or explosion could occur.
- NEVER modify the electric circuit system. Tampering with the electric system may cause a shock, fire or explosion or may permanently damage the system.
- Do not allow direct contact between battery terminals. Fire or explosion can occur.
- Do not allow any type of liquid on the battery or its components.
- Explosive gasses are created during charging. Do not charge near heat or flammable materials. Charge the battery in a well-ventilated area ONLY.
- NEVER pick up the battery by the wires or charger. Damage can occur to the battery and may cause a fire. Pick up the battery by the case ONLY.
- Charge the battery in a dry area ONLY.
- Battery posts, terminals and related accessories contain lead and lead compounds, chemicals known to the State of California to cause cancer and reproductive harm. **Wash hands after handling.**
- Do not open the battery. Battery contains lead acid and other materials that are toxic and corrosive.
- Do not open the charger. Exposed wiring and circuitry inside case may cause electric shock.
- Only adults may handle or charge the battery. NEVER allow child to handle or charge the battery. Battery is heavy and contains lead acid (electrolyte).
- Do not drop the battery. Permanent damage to the battery could occur or cause serious injury.
- Before charging the battery, check for wear or damage to the battery, charger, its supply cord and the connectors. DO NOT charge the battery if any damage to parts has occurred.
- Do not allow the battery to drain completely. Recharge the battery after each use or once a month if not used regularly.
- Do not charge battery upside down.
- Always secure the battery with the bracket. Battery can fall out and injure a child if vehicle tips over.

- The POWER SWITCH must be turned in **OFF** position when charging.
- Before the first use, you should charge the battery for 4-6 hours. Do not recharge the battery for more than 10 hours to avoid overheating the charger.
- When the vehicle begins to run slowly, recharge the battery.
- After each use or once a month minimum recharge time as 8 to 12 hours, less than 20 hours at most.

- If your ride-on with a **Digital voltmeter(IF EQUIPPED)**, the magnitude of voltage will tell you how much power is remaining in the battery when you must recharge the battery. Make sure the vehicle is stop!

BATTERY	MAGNITUDE OF VOLTAGE	BATTERY STATE
6V4Ahx1, 6V7Ahx1 6V10Ahx1	≥ 6.6	The battery is full.
	6.5~6.3	The vehicle can work normally.
	≤ 6.2	The battery needs to be charge.
6V4Ahx2, 6V7Ahx2, 6v10Ahx2,12V7Ahx1, 12V10Ah x1	≥ 13.2	The battery is full.
	13.1~12.6	The vehicle can work normally.
	≤ 12.5	STOP operating the vehicle, the battery needs to be charge.

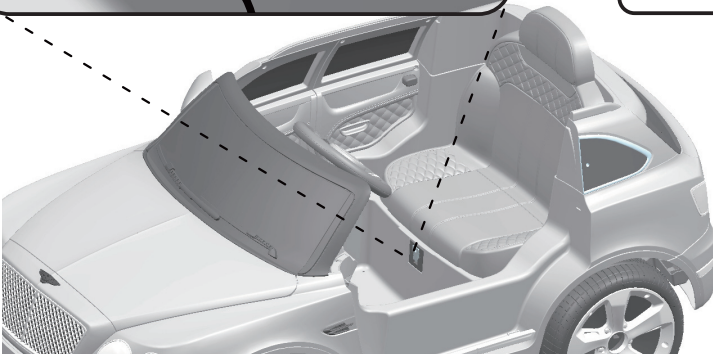
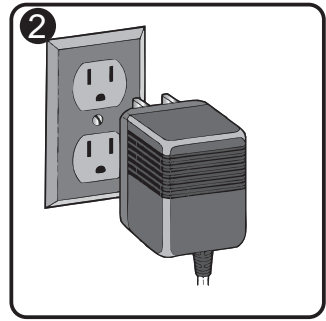
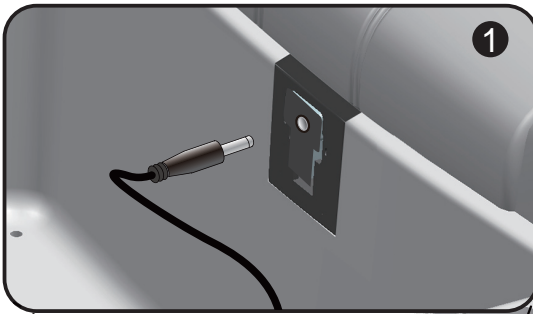

1. Plug the charger port into the input socket. (the socket is below the seat)

HINT: If your vehicle equipped with the Multi-function Dash, the Charging Socket is on the dash, please see page 15 <Use the Multi-function Dash>

2. Plug the charger plug into a wall outlet. The battery will begin charging.

⚠ **WARNING!**

This product with **Charging Protection**: when charging, all functions will be cut off! Only an adult can charge and recharge the battery!

The battery features a thermal fuse with a reset fuse that will automatically trip and cut all power to the vehicle if the motor, electric system or battery is overloaded. The fuse will reset and power will be restored after the unit is turned OFF for 20 seconds and then turned ON again. If the thermal fuse trips repeatedly during normal use, the vehicle may need repair. **Contact your distributor please.**

To avoid losing power, follow these guidelines:

- Do not overload the vehicle.
- Do not tow anything behind the vehicle.
- Do not drive up steep slopes.
- Do not drive into fixed objects, which may cause the wheels to spin, causing the motor to overheat.
- Do not drive in very hot weather, components may overheat.
- Do not allow water or other liquids to come in contact with the battery or other electric components.
- Do not tamper with the electric system. Doing so may create a short, causing the fuse to trip.

Battery Replacement and Disposal



The battery will eventually lose the ability to hold a charge. Depending on the amount of use, and varying conditions, the battery should operate for one to three years. Follow these steps to replace and dispose the battery:

1. Remove the car seat.
2. Disconnect the battery connectors.
3. Remove the battery bracket.
4. Remove the battery cover.
5. Carefully lift the battery.
 - Depending on the condition of the battery (i.e.: leakage) you may want to wear protective gloves before removal.
 - Do not lift the battery by its connectors or cables.
6. Place the dead battery in a plastic bag.

Important! Recycle the dead battery responsibly. The battery contains lead acid (electrolyte) and must be disposed of properly and legally. It is illegal in most areas to incinerate lead acid batteries or dispose of them in landfills. Take it to a federal or state-approved lead acid battery recycler, such as local automotive battery retailer. Do not throw the battery away with your regular household waste!

7. Replace the battery and reconnect the connectors.
8. Replace the metal battery bracket.
9. Replace the seat.

Problem	Possible Cause	Solution
Vehicle does not run	Battery low on power	Recharge battery.
	Thermal fuse has tripped	Reset fuse, see <Fuse>
	Battery connector or wires are loose	Check that the battery connectors are firmly plugged into each other. If wires are loose around the motor contact your distributor please.
	Battery is dead	Replace battery, contact your distributor please.
	Electrical system is damaged	Contact your distributor please.
	Motor is damaged	Contact your distributor please.
Vehicle does not run very long	Battery is under charged	Check that the battery connectors are firmly plugged into each other when recharging
	Battery is old	Replace battery, contact your distributor please.
Vehicle runs sluggishly	Battery low on power	Recharge battery, contact your distributor please.
	Battery is old	Replace battery, contact your distributor please.
	Vehicle is overload	Reduce weight on vehicle. Maximum user weight is 30 kgs.
	Vehicle is being used in harsh conditions	Avoid using vehicle in harsh conditions ,see <Safety>.
Vehicle needs a push to go forward	Poor contact of wires or connectors	Check that the battery connectors are firmly plugged into each other. If wires are loose around the motor, contact your distributor please.
	“Dead Spot” on motor	A dead spot means the electric power is not being delivered to the terminal connection and the vehicle needs repair. Contact your distributor please.
Difficult shifting from forward to reverse or vice-versa	Attempting to shift while the vehicle is motion	Completely stop the vehicle and shift, see <Use Your Ride-On>
Loud grinding or clicking noises coming from motor or gear box	Motor or gears are damaged	Contact your distributor please.
Battery will not recharge	Battery connector or adapter connector is loose	Check that the battery connectors are firmly plugged into each other.
	Charger not plugged in	Check that the battery charger is plugged into a working wall outlet.
	Charger is not working	Contact your distributor please.
Charger feels warm when recharging	This is normal and not a cause for concern	

Completely read through this manual and the troubleshooting guide table before calling. If you still need help resolving the problem **Contact your distributor please.**

- It is parents' responsibility to check main parts of the toy before using, Must regularly examine for potential hazard, such as the battery, charge, cable or cord, plug, screws are fastening enclosure of other parts and that in the event of such damage, the toy must not be used until that damage had been properly removed.
- Make sure the plastic parts of the vehicle are not cracked or broken.
- Occasionally use a lightweight oil to lubricate moving parts such as wheels.
- Park the vehicle indoors or cover it with a tarp to protect it from wet weather.
- Keep the vehicle away from sources of heat, such as stoves and heaters. Plastic parts may melt.
- Recharge the battery after each use. Only an adult can handle the battery. Recharge the battery at least once a month when the vehicle Raider is not being used.
- Do not wash the vehicle with a hose. Do not wash the vehicle with soap and water. Do not drive the vehicle in rainy or snowy weather. Water will damage the motor, electric system and battery.
- Clean the vehicle with a soft, dry cloth. To restore shine to plastic parts, use a non-wax furniture polish. Do not use car wax. Do not use abrasive cleaners.
- Do not drive the vehicle in loose dirt, sand or fine gravel which could damage the moving parts, motors or the electric system.
- When not using, all the electrical source should be turn off. Turn off the power switch and disconnect the battery connection.



BENTLEY

Our products are suitable for
ASTM F963; GB6675; EN71 and EN62115 standard.