

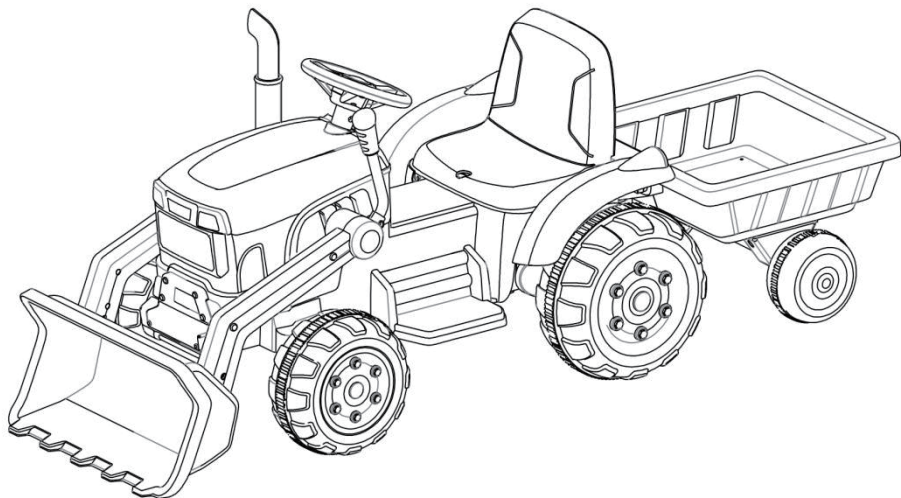

# FREDDO

## EXCAVATOR



**Styles and colors may vary**

- ◎ Suitable age for 3-8 Years
- ◎ Maximum user weight: 30KGS/66LBS
- ◎ Adult assembly required

# INSTRUCTION MANUAL

Charge for 4-6 hrs before initial use.

After initial charge, follow the normal recommended charging time.

Tips: due to different configurations, the number of screw, gaskets is also different. Please install them according to the contents of the manual, and the rest are for standby.

## **SAFETY**

Please retain these instructions for future reference.

**NOTE:**For best performance,only use this vehicle on flat and hard surfaces.

**AGE RANGE:**3 to 8 years old

**WEIGHT CAPACITY:**30KGS/66LBS is the maximum weight for 1 rider

The following safety hazards may result in serious injury or death:

- This product contains small parts.Keep children away during assembly.Make sure to remove all packaging material and parts from underneath the vehicle body.
- Never open the battery.Batteries contain lead and lead compounds(acids).
- Limbs,hair,and clothing can get caught in moving parts.Always wear shoes,keep limbs away from moving parts,and do not wear loose clothing while operating this vehicle.
- This vehicle does not have brakes or braking capability.Do not leave a child unattended during operation.DO not use this in a location that may require braking capability.as this could result in loss of control,which may cause serious injury or death.
- Use of this vehicle near streets,motor vehicles,steps,bodies of water,sloped surfaces,hills,wet areas,flammable vapors,in alleys,at night,or in the dark could result in an unexpected accident.
- Usu of this vehicle in unsafe conditions such as snow,rain,loose dirt,mud.sand,or gravel may result in an unexpected accident such as tipping over,and could damage the electrical system or battery.
- Do not operate this vehicle in an unsafe manner.Examples include but are not limited to:
  - pulling the vehicle with another vehicle or similar device
  - Pushing the user
  - Traveling at an unsafe speed

## BATTERY WARNINGS

The following safety hazards may result in serious injury or death:

- Use of a battery or charger other than the supplied rechargeable battery and charger may cause a fire or explosion. Only use the supplied battery and charger.
- Use of the rechargeable battery and charger for any other product may result in overheating, fire, or explosion. Never use the supplied rechargeable battery and charger with another product.
- Explosive gases are created during charging. Charge the battery in a well-ventilated area. Do not charge the battery near heat or flammable materials.
- Contact between the positive and negative terminals may result in fire or explosion. Avoid direct contact between the terminals. Picking up the battery by the wires or charger can cause damage to the battery and may result in a fire. Always pick up the battery by its case or handles.
- Liquids on the battery may cause fire or electric shock. Always keep all liquids away from the battery and keep the battery dry. Contact or exposure to battery leakage (lead acid) may cause serious injury. If contact or exposure occurs immediately call your physician. If the chemical is on the skin or in the eyes, flush with cool water for 15 minutes. If the chemical was swallowed, immediately give the person water or milk. Do not give water or milk if the patient is vomiting or has a decreased level of alertness. Do not induce vomiting.
- Battery posts, terminals, and related accessories contain lead and lead compounds (acid)
- Tampering or modifying the electric circuit system may cause a shock, fire or explosion and permanently damage the system. Exposed wiring and circuitry in the charger may cause electric shock. Always keep the charger housing closed.

## USER WARNINGS

The following safety hazards may result in serious injury or death:

- Never leave a child unattended.
- Always sit in the seat when using this vehicle.
- Keep your hands, hair, and clothes away from moving parts.
- Always wear shoes when operating this vehicle.
- Children under 3 years of age cannot use the vehicle.
- Only drive on level ground.
- Do not go near swimming pools or other bodies of water, drop-offs, or up and down steep inclines.
- Do not drive the vehicle into loose dirt, mud, sand, fine gravel, or on wet surfaces.
- Do not drive the vehicle on streets or near cars.

## SPECIFICATIONS

Item	Specification
Batteries	12V 4.5AH
Motor	12V(30W*2)
Age	3-8years
Max Weight	30KGS/66LBS
Dimension	146*58*58.5CM/57.4*22.8*23INCH
Speed	2.5-3.5 KMH/1.5-2.2 MPH
Play Time	1-2 hours / recharger time 8-12hours
Charger	Output DC 12V



## TOOLS REQUIRED

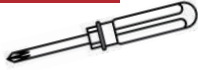

SCREWDRIVER  
(PROVIDED)



M10 WRENCH  
(PROVIDED)



2 PERSON  
ASSEMBLY



APPROXIMATELY  
45 MIN.  
ASSEMBLY

## HARDWARE

1

M4\*10mm  
SCREW

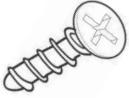

10 PCS

2

$\phi$  10 GASKETS



13 PCS

3

M10 NUTS



8 PCS

4

M4\*20mm  
SCREW



2 PCS

5

M5\*35mm  
SCREW



2 PCS

6

M5 NUTS



2 PCS

7

COTTER PIN



1 PCS

## PARTS

A

FRONT WHEEL



2 PCS

B

REAR WHEEL

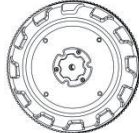

2 PCS

C

REAR BUCKET  
WHEEL



2 PCS

D

FRONT WHEEL  
COVER



2 PCS

E

REAR WHEEL COVER

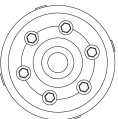

2 PCS

F

REAR BUCKET  
WHEEL COVER



2 PCS

G

BUCKET

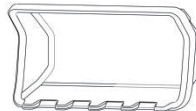

1 PCS

H

REMOTE CONTROL



1 PCS

**I**

CHARGERS



1 PCS

**J**

BUCKET ARM  
(LEFT)

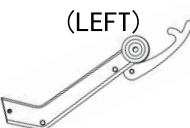

1 PCS

**K**

BUCKET ARM  
(RIGHT)

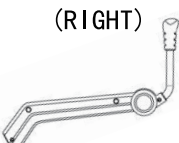

1 PCS

**L**

BUCKET ARM  
COVER



2 PCS

**M**

SEAT



1 SET

**N**

CHIMNEY

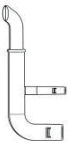

1 PCS

**O**

STEERING WHEEL



1 PCS

**P**

CAR BUCKET



1 PCS

**Q**

CAR BUCKET  
CONNECTION



1 PCS

**R**

BODY CONNECTION



1 PCS

**S**

CAR BUCKET LATCH



1 PCS

**T**

REAR AXLE



1 PCS

**U**

GEAR BOX (L/R)

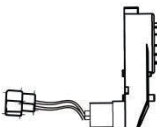

2 PCS

**V**

CAR BUCKET AXLE  
FIXED SEAT



2 PCS

**W**

CAR BUCKET AXLE



1 PCS

**X**

AUDIO CABLE

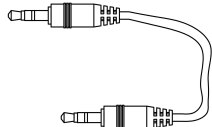

1 PCS

**Y**

STEERING LEVER



1 PCS

## PRODUCT ASSEMBLY

Turn over the body so that its body faces up.

### Y Fix the steering lever.

- Insert the steering lever into the body hole.
- Insert  $\phi 10$  washer on steering lever.
- After the steering lever is installed in place, insert the cotter pin to bend and fix it.

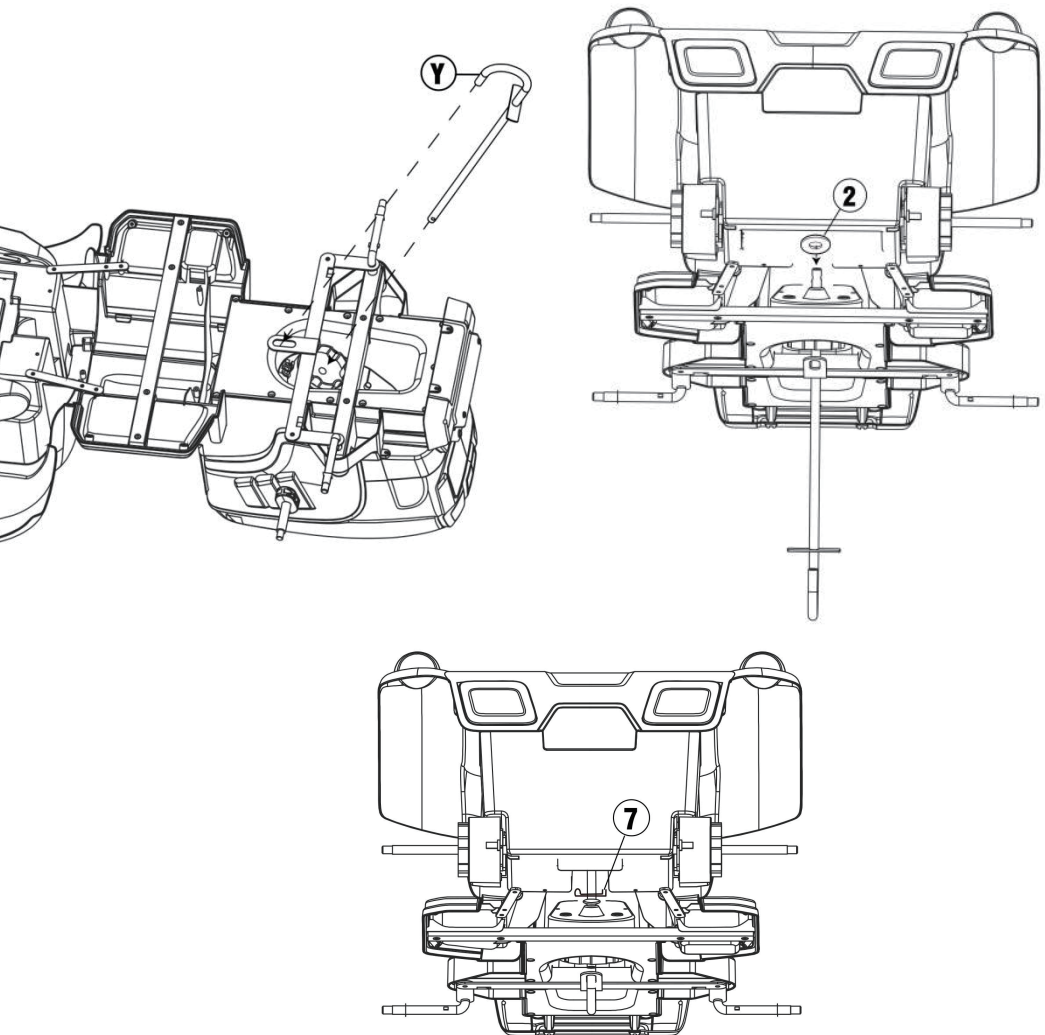

## PRODUCT ASSEMBLY

Turn over the body so that its body faces up.

**T** Fix the rear axle.

- Insert the rear axle into the car.

**U** Fix the gear box (L/R)

- Put the gear box into the rear axle, and clip the motor and motor wire into the body slot. (Note: the gear box is distinguished from the left and right)

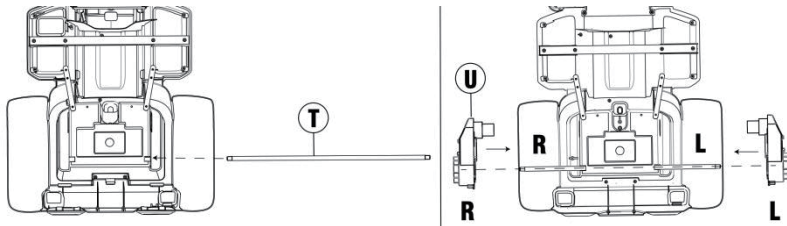

Put the gaskets, front wheel, gaskets and nut into the front axle in turn.

Fix the nut with the M10 wrench and then attach the front wheel cover to the wheel.

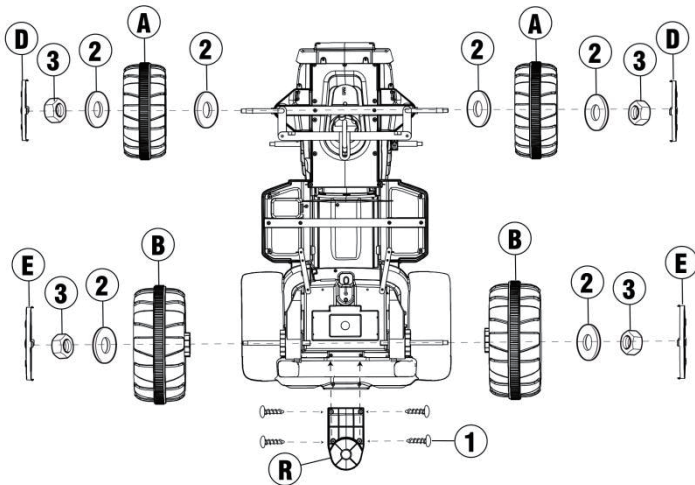

Place the rear wheel, gaskets, and nut on the rear axle in turn.

Fix the nut with the M10 wrench and then attach the rear wheel cover to the wheel.

Clip the body connection into the body and use M4 \* 10mm Screw fixation.

## PRODUCT ASSEMBLY

Turn over the body so that its body faces up.

**(N)** Fix the chimney.

- Clip chimney into the body slot.

**(J)** **(K)** **(L)**

Put the bucket arm, gaskets and nut into the bucket axle in turn.

Fix the nut with the M10 wrench and then attach the bucket arm cover to the bucket arm . (Note: the bucket arm is divided into left and right, as shown in the figure. When installing the bucket arm, press hard.)

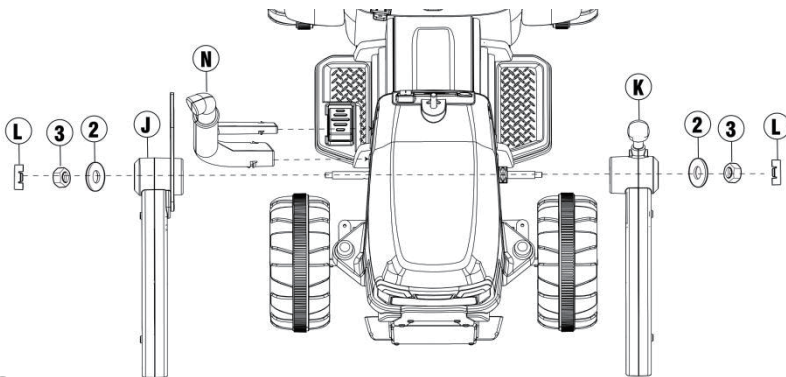

**(G)** Fix the bucket.

- Clip the bucket into the bucket arm.
- As shown in the figure: And fix it with M5 \* 35mm screw and M5 nuts.

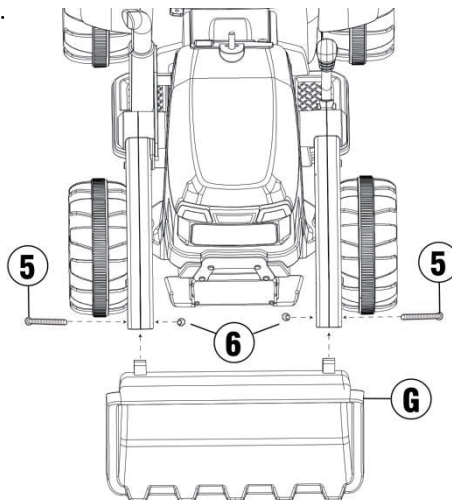

## PRODUCT ASSEMBLY

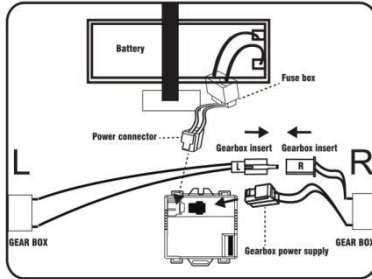

1. Find out the main power line under the seat, insert the plug-in of the power line into the corresponding socket of the receiver, connect one end of the right drive motor line with the left drive motor line, and insert the other plug-in on the right into the socket of the receiver.

**O** Fix the steering wheel.

- Remove the nut and bolt from the steering wheel.
- Connect the wires coming from the steering column to the wires on the steering wheel.
- Insert the steering wheel over the steering and secure with nut and bolt.

**M** Fix the seat.

- Merge seat.
- Clip the seat into the body.
- Rotate the latch on the seat to secure the seat.

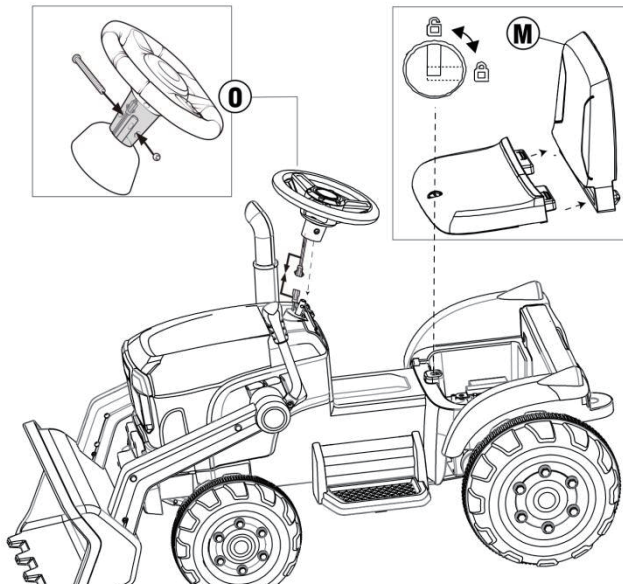

## PRODUCT ASSEMBLY

W C F

Fix the rear bucket wheel、rear bucket wheel cover.

- Put the gaskets, bucket wheel, gaskets and nut into the car bucket axle in turn.
- Fix the nut with the M10 wrench and then attach the bucket wheel cover to the bucket wheel.

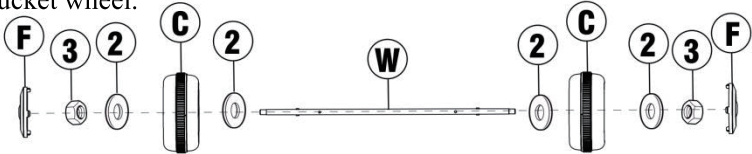

Q Fix the car bucket connection.

- Clip the car bucket connection into the car bucket and fix it with M4 \* 10mm screw.

V Fix the car bucket axle fixed seat.

- Clip the car bucket axle fixed seat into the car bucket and fix it with M4 \* 10mm screw.(Note: pay attention to the direction when installing car bucket axle fixed seat, as shown in the figure)

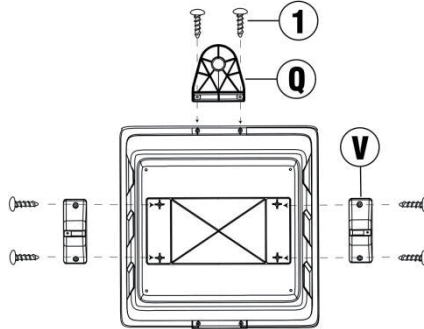

4 Fix the car bucket axle.

- Clip the car bucket axle into the car bucket axle fixed seat and fix it with M4 \* 20mm screw.

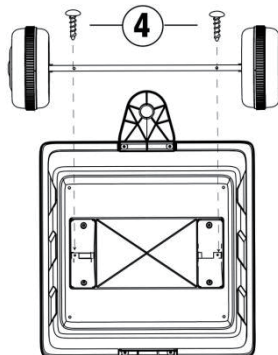



## PRODUCT ASSEMBLY

### S Fix the car bucket latch.

- Connect the vehicle body with the car bucket, clip it into the car bucket latch, rotate the car bucket latch fix it.

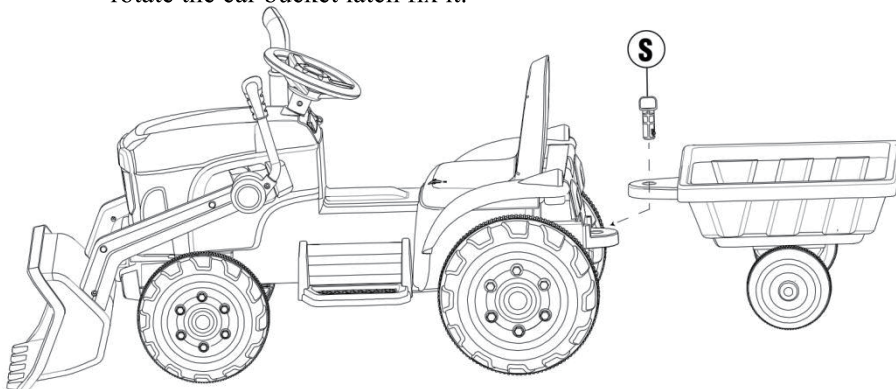

## DASHBOARD DIAGRAM

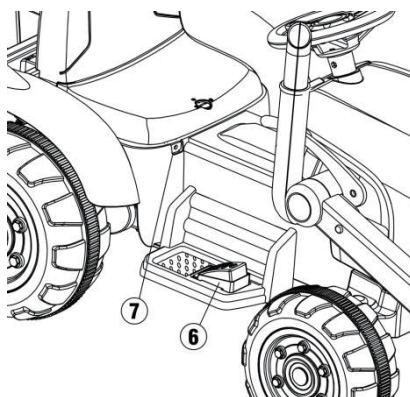
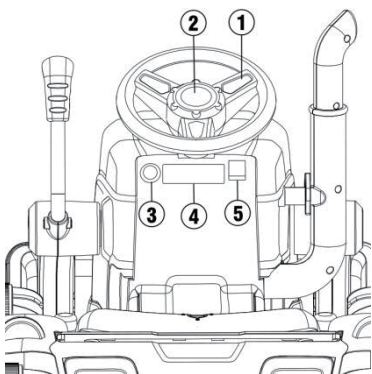

1. Music Button:press it to play music;
2. Horn button:press to play the horn;
3. Power button:can turn the vehicle on or off;
4. Control board:
5. Shift Switch:Change the direction of the car , Forward-Backward;
6. Pedal button: Step on the button , the car will move,when release the car slowly stop;
7. Socket: charge;



## DASHBOARD DIAGRAM

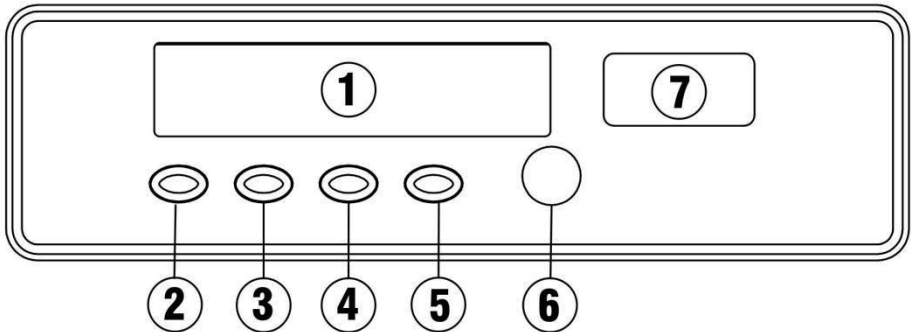

Central control panel:

- 1.Power display:Clearly see the battery power, in order to charge; the smaller the number, the lower the voltage. Please charge in time;
- 2.Last song/Volume decrease:Change songs, and long press will decrease volume;
- 3.Play or stop switch;
- 4.Next song/Volume increase: Change songs, and long press will increase volume;
- 5.Mode switch: press to switch mode/music mode/radio mode/Wireless Technology;
- 6.MP3:the data cable can be connected to other devices and play music;
7. U:Multimedia Input

## REMOTE CONTROL DIAGRAM

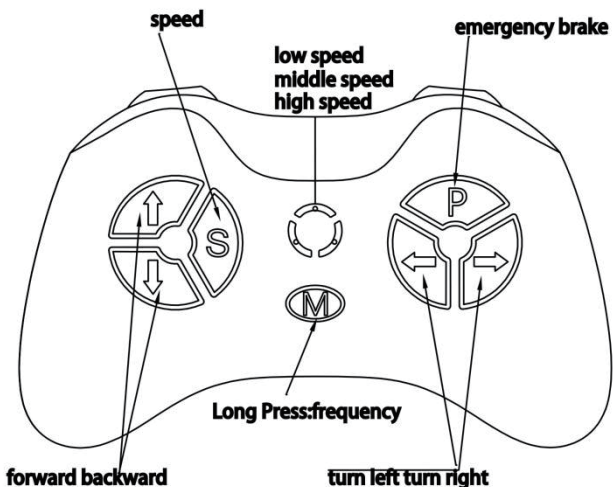

### Warning

Only used by adults

**Remote control first. When the remote control is on, foot pedal is not workable**

#### **Operation Manual:**

Take out the remote control, Open the battery compartment on the back of the remote control and add two AAA LRO3 alkaline batteries. Pay attention to the polarity of the batteries. When the alignment light and speed indicator light up, it indicates that the battery installed is correct. This product does not provide dry batteries.

#### **<Button Description >**

(1) Long press on the frequency key(M) 2-4 seconds, Low speed LED light flashing. Turn on the power of the car, Low speed LED light keep flashing to long lighting, then frequency bind succeed. If the frequency bind failed (Low speed LED light flashing) , remove the battery and repeat steps

P: Press to brake。

S: Speed: press to change speed(low,middle and high speed).

△Forward ▽backward。

◁ Turn left ▷ turn right

- 2) Brake button: Press it to stop moving; press it again to move.
- 3) Speed selection key and speed indication: used to select speed of the car. Press the key once to switch the speed once. 3 speeds are cyclically switched, and the switching sequence is: low-medium-high. The speed indicator is arranged from top to bottom on the remote control: high-speed lamp, medium-speed lamp, low-speed lamp; when switching to one speed, the corresponding indicator lamp will light up. Note: The speed grade changes only when moving forward
- 4) Forward/backward keys: used for forward and backward movement control. When one of the keys is pressed, the moving speed will slowly increase to reach the set speed level. Therefore, children will not have a sudden impact.
- 5) Left turn/right turn key: used for left and right direction control.

**Note:** without operation after 10 seconds, indication light will off into power saving mode

 **WARNING:** The remote control is not a toy. It is for the adult use only, and should not be used by a child. A close adult supervision is always required. Reception range may change significantly with weather, battery, and other environmental conditions.

## CHARGING INSTRUCTIONS

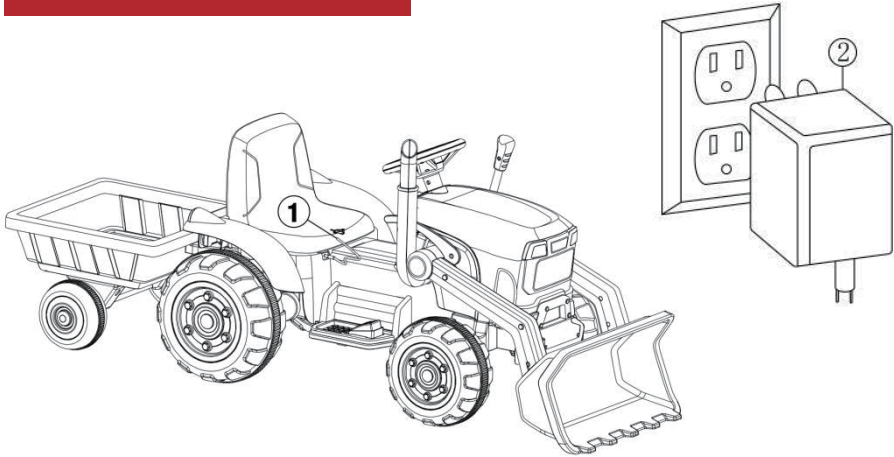

1. Insert the charger jack into the charging hole of the car.
2. Plug the charger plug into the stable matching AC power supply as shown in the picture.

- Charge the battery 15 to 18 hours before initial use.
- On average, you will need to charge the battery between 8 and 12 hours. Do not charge the battery for more than 20 hours. Failure to charge the battery as directed could cause permanent damage to the battery and void the warranty.
- Damage to the battery may occur if it is allowed to drain completely. Do not allow the battery to drain completely.
- Check the battery and charger (supply cord, connector) for wear and damage before charging. DO not charge the battery if damage has occurred.
- Only an adult who has read and understood the safety warnings should handle, charge and recharge the battery.

## CARING FOR YOUR RIDE-ON

- Park the vehicle indoors or cover it with a tarp to protect it from wet weather.
- Do not leave the vehicle in the sun for long periods of time or fading may occur. Store in shade or cover with tarp.
- Do not wash the vehicle with a hose.
- Do not wash the vehicle with soap.
- Charge battery at least once a month to prolong the life of the battery.

## TROUBLESHOOTING

PROBLEM	REASON	SOLUTION
Vehicle does not move	Low battery	Fully charge the battery
	Electrical protection	Stop use for several minutes and restart
	Switch not in the correct position	Completely press in switches
	Battery connectors disconnected	Plug in battery connectors
Battery does not recharge	Battery connectors disconnected	Plug in battery connectors
	Charge not connected to socket or outlet	Completely plug in the charger
Battery does not last	Battery does not have a full charge	Fully charge the battery
Battery is warm and makes a slight noise while charging	Normal	Normal
Slow speed	Low battery	Fully charge the battery
	Overloaded vehicle	Reduce the weight on the vehicle
	Uneven or sloped road	Drive on flat pavement
Vehicles shakes while driving	Loose connection to motor	Ensure the motor is properly connected to the battery
Difficulty shifting between forward/reverse	Attempting to shift while vehicle in motion	Only shift when the vehicle is at a stop
Forward and reverse switch is flipped	Gear boxes are installed incorrectly	Make sure the L gear box is on the left and R gear box is on the right

## WARNINGS REGARDING BATTERIES

The battery on the vehicle is not replaceable.

- DO not mix old and new batteries.  
DO not mix alkaline,standard(carbon-zinc),or rechargeable batteries.
- Non-rechargeable batteries should not be charged.
- Rechargeable batteries should be charged under adult supervision only.
- Exhausted batteries should be removed.
- The supply terminals should not be short-circuited.
- Do not put batteries next to or in a heat source(fire,electronic heating device,etc.)
- Do not hit batteries against hard objects.
- Do not submerge batteries in water.
- Batteries should be inserted with the correct polarity.
- Only use the battery specified by the manufacturer.
- Only use the charger specified by the manufacturer.



### WARNING:

- Protective equipment should be worn.Not to be used in traffic.
- The toy should be used with caution since skill is required to avoid falls or collisions causing injury to the user or third parties.
- To reduce the risk of injury,adult supervision is required.Never use in roadways.near motor vehicles,on or near steep inclines or steps,swimming pools or other bodies of water;always wear shoes,and never allow more than 1 rider.

 **WARNING:** ADULT ASSEMBLY REQUIRED

 **WARNING:** Not to be used in traffic

 **WARNING:** CHOKING HAZARD-Small parts.  
Not for children under 3yrs.

## FCC Statement

### Caution:

This device complies with Part 15 of the FCC Rules. Operation is subject to the following two conditions: (1) this device may not cause harmful interference. (2) this device must accept any interference received, including interference that may cause undesired operation.

Changes or modifications not expressly approved by the party responsible for compliance could void the user's authority to operate the equipment.

This equipment has been tested and found to comply with the limits for a Class B digital device, pursuant to part 15 of the FCC Rules. These limits are designed to provide reasonable protection against harmful interference in a residential installation. This equipment generates uses and can radiate radio frequency energy and, if not installed and used in accordance with the instructions, may cause harmful interference to radio communications. However, there is no guarantee that interference will not occur in a particular installation. If this equipment does cause harmful interference to radio or television reception, which can be determined by turning the equipment off and on, the user is encouraged to try to correct the interference by one or more of the following measures:

- Reorient or relocate the receiving antenna.
- Increase the separation between the equipment and receiver.
- Connect the equipment into an outlet on a circuit different from that to which the receiver is connected.
- Consult the dealer or an experienced radio/TV technician for help.